

S6081 June  
WASSCE 2008  
TECHNICAL  
DRAWING 1

1

2 1/2 hours

Name:.....

Index Number:.....

**THE WEST AFRICAN EXAMINATIONS COUNCIL**  
West African Senior School Certificate Examination

June 2008

TECHNICAL DRAWING 1

2 1/2 hours

*Do not open this booklet until you are told to do so. While you are waiting, write your name and index number in the spaces provided at the top right-hand corner of this booklet and thereafter, read the following instructions carefully. This paper consists of two sections, A and B, answer Section A on your objective test answer sheet, and section B on the drawing paper provided. Section A will last for 1 hour after which the answer sheet will be collected. Do not start Section B until you are told to do so.*

**Section B will last for 1 1/2 hours.**

SECTION A  
OBJECTIVE TEST  
[40 marks]

1 hour

1. Use **HB pencil** throughout.
2. If you have got a blank answer sheet, complete its top section as follows.
  - (a) In the space marked *Name*, write in capital letters your **surname** followed by your **other names**.
  - (b) In the spaces marked *Examination, Year, Subject and Paper*, write 'WASSCE', '2008 JUNE', 'TECHNICAL DRAWING' and '1', respectively.
  - (c) In the box marked *Index Number*, write your **index number** vertically in the spaces on the left-hand side. There are numbered spaces in line with each digit. Shade carefully the space with the same number as each digit.
  - (d) In the box marked *Paper Code*, write the digits **60812** in the spaces on the left-hand side. Shade the corresponding numbered spaces in the same way as for your index number.
  - (e) In the box marked *Sex*, shade the space marked **M** if you are **male**, or **F** if you are **female**.
3. If you have got a pre-printed answer sheet, check that the details are correctly printed, as described in 2 above. In the boxes marked *Index Number, Paper Code and Sex*, **reshade** each of the shaded spaces.
4. An example is given below. This is for a **male** candidate whose **name** is **Chukwuma Adekunle CIROMA**, whose **index number** is **4251102068** and who is offering **Technical Drawing 1**.

**THE WEST AFRICAN EXAMINATIONS COUNCIL**

PRINT IN BLOCK LETTERS

Name: CIROMA CHUKWUMA ADEKUNLE Examination: WASSCE Year: 2008 JUNE  
Surname Other Names

Subject: TECHNICAL DRAWING Paper: 1

INDEX NUMBER	
4	0 1 2 3 4 5 6 7 8 9
2	0 1 2 3 4 5 6 7 8 9
5	0 1 2 3 4 5 6 7 8 9
1	0 1 2 3 4 5 6 7 8 9
1	0 1 2 3 4 5 6 7 8 9
0	0 1 2 3 4 5 6 7 8 9
2	0 1 2 3 4 5 6 7 8 9
0	0 1 2 3 4 5 6 7 8 9
6	0 1 2 3 4 5 6 7 8 9
8	0 1 2 3 4 5 6 7 8 9

PAPER CODE	
6	0 1 2 3 4 5 6 7 8 9
0	0 1 2 3 4 5 6 7 8 9
8	0 1 2 3 4 5 6 7 8 9
1	0 1 2 3 4 5 6 7 8 9
1	0 1 2 3 4 5 6 7 8 9
2	0 1 2 3 4 5 6 7 8 9

SEX	
M	F

Indicate your sex by shading the space marked M (for Male) or F (for Female) in this box: M F

- INSTRUCTIONS TO CANDIDATES**
1. Use grade **HB pencil** throughout.
  2. Answer each question by choosing one letter and shading it like this: [A] [B] [C]
  3. Erase completely any answers you wish to change.
  4. Leave extra spaces blank if the answer spaces provided are more than you need.
  5. Do not make any markings across the heavy black marks at the right-hand edge of your answer sheet.

**For Supervisors only.**  
If candidate is absent shade this space:

Answer forty questions in all: all the questions in Part 1 and ten questions only from either Part IIA or Part IIB.

Each question is followed by four options lettered A to D. Find out the correct option for each question and shade in pencil on your answer sheet, the answer space which bears the same letter as the option you have chosen. Give only one answer to each question. An example is given below.

The part of a building immediately above a window frame is the

- A. wall plate.
- B. king post.
- C. lintel.
- D. wall

The correct answer is lintel which is lettered C and therefore answer space C would be shaded.

[A]                      [B]                       [C]                      [D]

Think carefully before you shade the answer spaces; erase completely any answer(s) you wish to change.

Do all rough work on this question paper.

PART 1

Answer all the questions in this part.

1. Which of the following shows a centre line?



2. Which of the following shows the curve of interpenetration of two unequal cylinders?

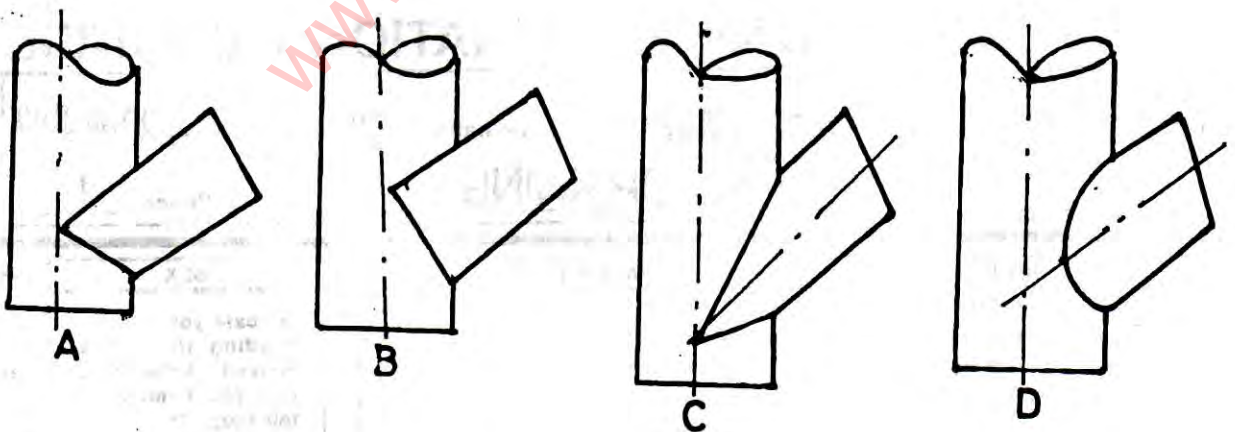

3. How many faces has a solid hexagonal pyramid?

- A. 4
- B. 5
- C. 6
- D. 7





4

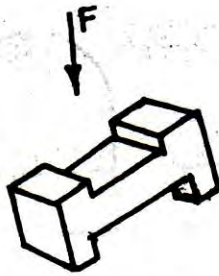

8. The plan of the figure above in the direction of arrow F is

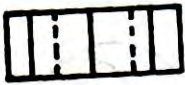

A



B

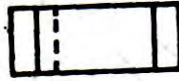

C



D

9. Which of the following is required to construct the polygon below?

- A. Distance across flats
- B. Distance across corners
- C. Internal angle
- D. Length of one side

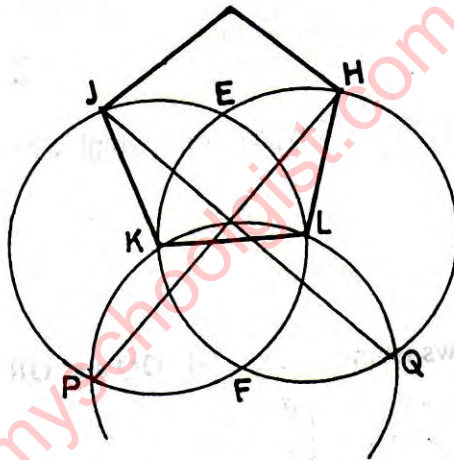

10. Which of the following drawing instruments is used to reproduce shapes?

- A. Compass
- B. Template
- C. Divider
- D. Protractor

11. Which of the following curves has eccentricity greater than one?

- A. T
- B. S
- C. V
- D. U

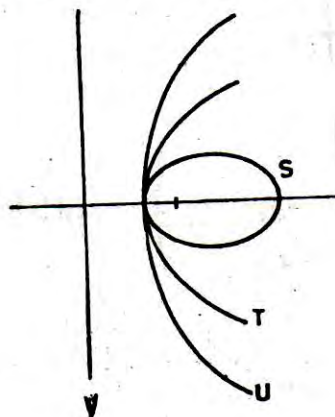

12. If the crank **OK** in the diagram below moves anticlockwise the link **KP** will

- A. rotate at **Q**
- B. slide towards **K**
- C. slide towards **P**
- D. remain stationary

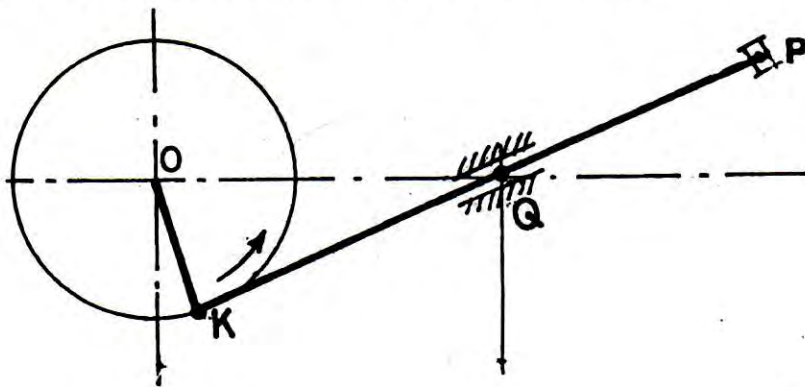

13. Which of the following is an example of a frustum?

- A. Water bucket
- B. Electric bulb
- C. Lantern
- D. Fluorescent tube

14. The development of a closed square prism will have

- A. 4 rectangles and 4 squares.
- B. 2 squares and 2 rectangles.
- C. 4 rectangles and 2 squares.
- D. 4 squares and 2 rectangles.

15. If a length of 1 metre on land is represented by 2 cm on a drawing, what is the ratio of the scale used?

- A. 1:20
- B. 1:40
- C. 1:50
- D. 1:100

16. Which of the following has eight triangular faces?

- A. Octahedron
- B. Tetrahedron
- C. Hexahedron
- D. Decahedron

17. What type of section is suitable for showing the cross-section of a long bar?

- A. Removed
- B. Half
- C. Offset
- D. Revolved

18. Which of the following is the true shape of the section S-S above if the object is spherical?

- A. Circle
- B. Ellipse
- C. Triangle
- D. Sphere

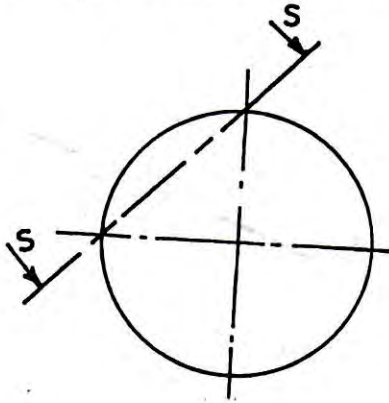

19. A conic section whose eccentricity is  $\frac{4}{3}$  is a/an

- A. hyperbola.
- B. parabola.
- C. sphere.
- D. circle.

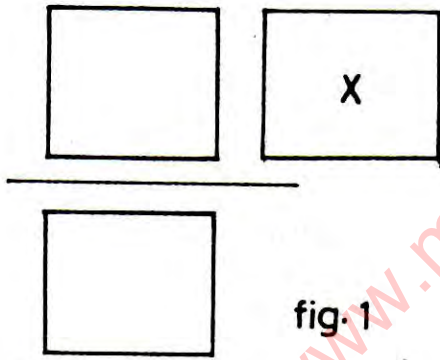

fig. 1

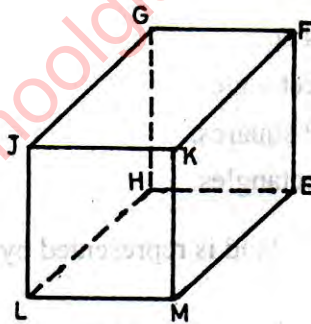

fig. 2

20. If the rectangular tank in figure 2 above is projected in first angle, the view X in figure 1 represents surface

- A. JKML
- B. GHEF
- C. GFKJ
- D. EFKM

21. Which of the following polygons has one of its internal angles more than  $180^\circ$ ?



A

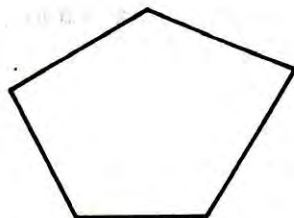

B

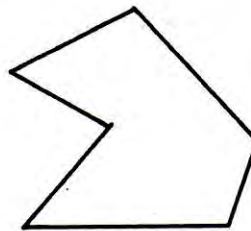

C

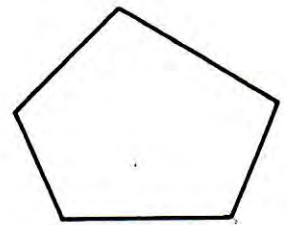

D



22. Which of the following is a circumscribed circle?

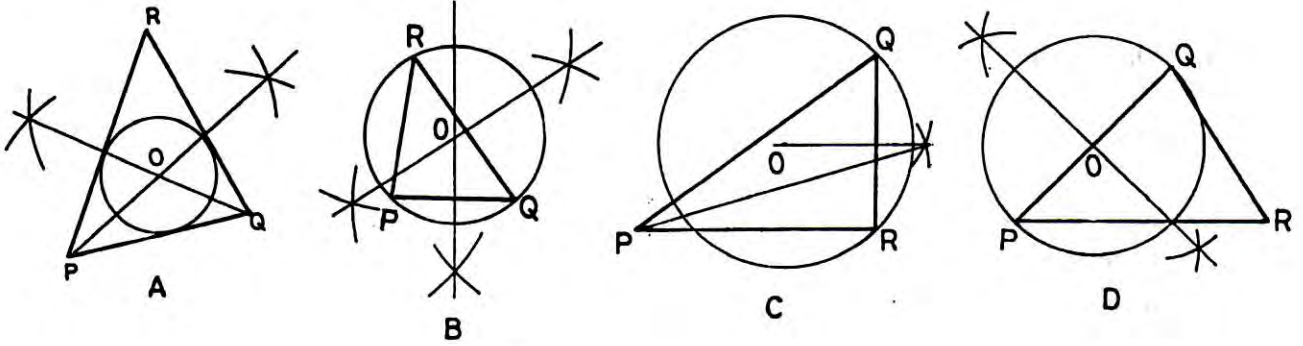

23. If a right cone is truncated by a cutting plane which is perpendicular to its axis, then the true shape of the cut surface is a/an

- A. ellipse.
- B. circle.
- C. semi-circle.
- D. parabola.

24. The figure below shows a trough. It comprises

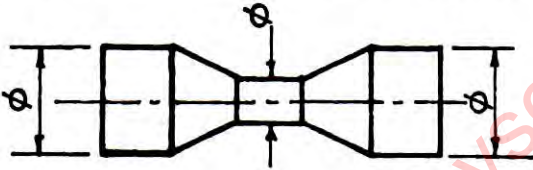

- A. two truncated cones and three truncated cylinders.
- B. two truncated cones and three cylinders.
- C. two cones and three cylinders.
- D. three cones and three cylinders.

25. Which of the following plan figures is **not** represented in the figure below?

- A. Trapezium
- B. Square.
- C. Rhombus
- D. Rectangle

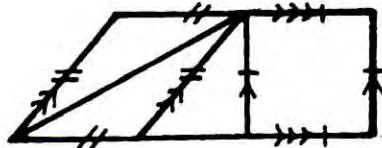

26. The point where a line penetrates a plane is called the

- A. incident.
- B. trace.
- C. axis.
- D. directrix

27. Which of the following is not a type of scale?

- A. Scale of chords
- B. Plain scale
- C. Diagonal scale
- D. Parallel scale

28. The head lamp of a car is constructed by applying the principle of

- A. hyperbola.
- B. parabola.
- C. involute.
- D. cycloid.

29. The construction below cannot be used to

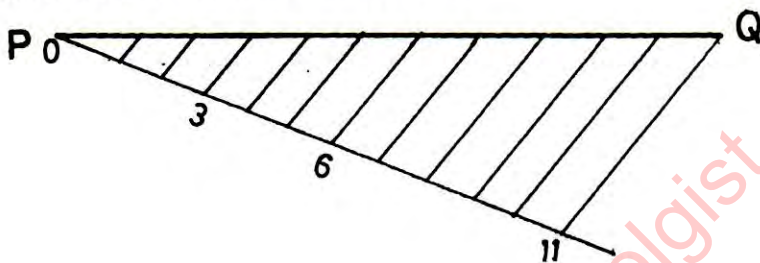

- A. determine the mid-point of line PQ.
- B. divide line PQ into eleven equal parts.
- C. construct a triangle whose sides are in ratio 3:5:3
- D. construct a triangle whose perimeter is equal to line PQ.

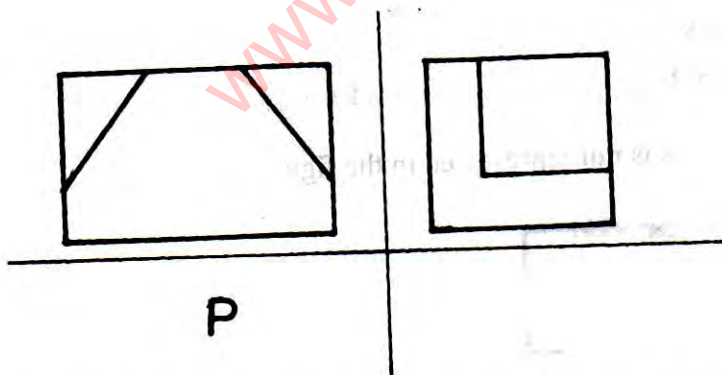

30. The figure above shows a box in orthographic view. The correct view in the position P is

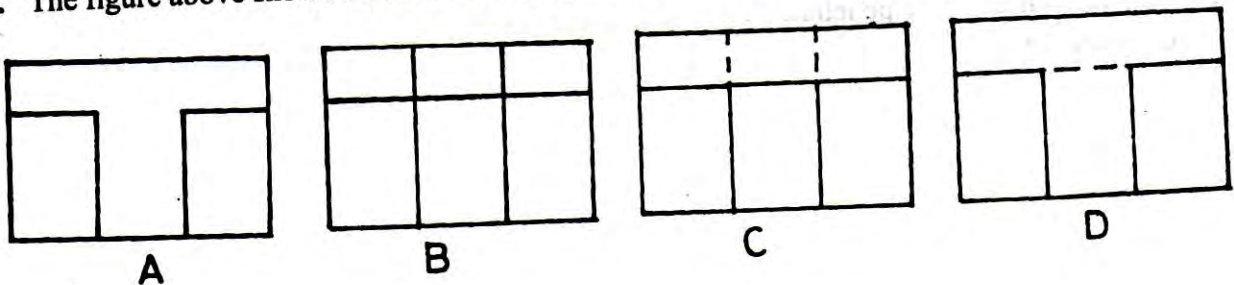



PART II A  
BUILDING DRAWING (Optional)

31. The figure below shows part of a section through a roof and wall. The part labelled S is called

- A. purlin.
- B. reinforced concrete.
- C. wallplate.
- D. lintel.

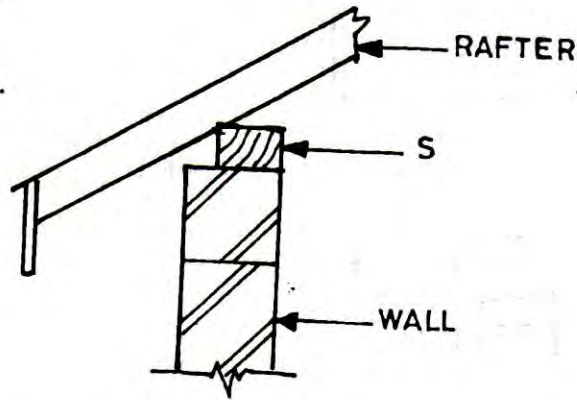

Use the figure below to answer questions 32 and 33.

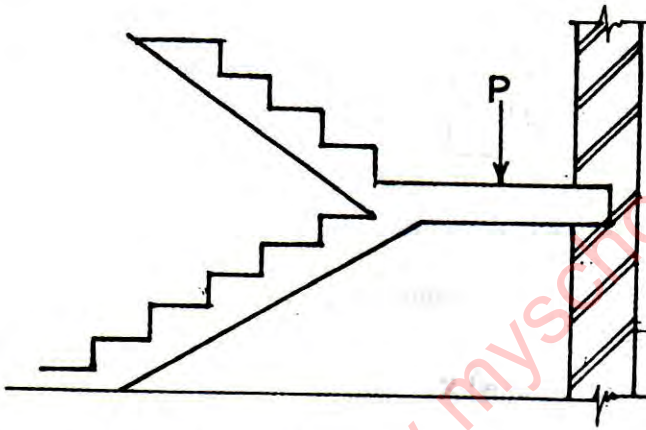

32. The part labelled P is the

- A. going.
- B. thread.
- C. landing.
- D. flight.

33. How many flights are in the stair case?

- A. Six
- B. Five
- C. Four
- D. Two

34. Which of the following is **not** a type of door?

- A. Raft
- B. Brazen
- C. Battern
- D. Ledged

35. The material symbol shown below represents

- A. wood
- B. brick
- C. concrete
- D. glass

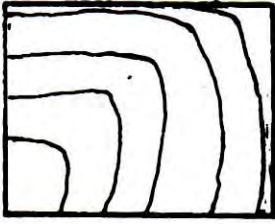

36. In the double casement window shown below the stile is labelled

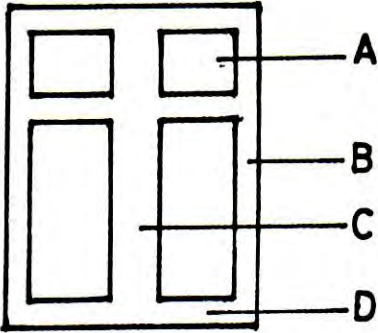

37. Which of the following is not a member of a roof?

- A. Queen post
- B. Jamb
- C. Purlin
- D. Wallplate

38. In the staircase shown below identify the part labelled X.

- A. Riser
- B. Flight.
- C. Going
- D. Landing

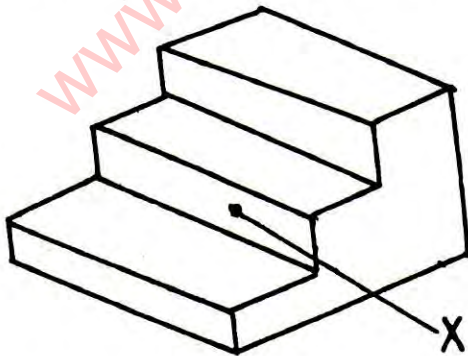

39. Soffit is a member of a

- A. foundation.
- B. roof.
- C. floor.
- D. wall.

40. The part labelled Q in the figure below is called

- A. rafter.
- B. wallplate
- C. kingpost
- D. purlin

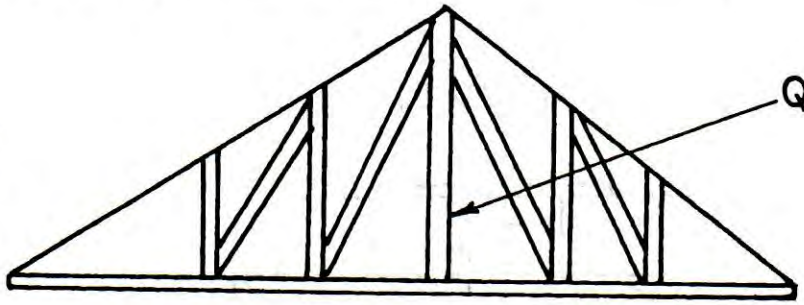

PART II B

MECHANICAL DRAWING (Optional)

31. The portion marked X in the figure below is

- A. relessed.
- B. countersink.
- C. chanfered.
- D. spot faced.

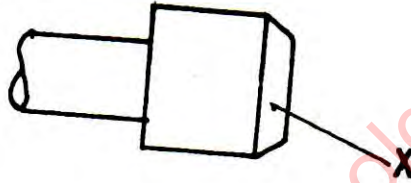

Use the figure below to answer questions 32 and 33.



32. What type of thread form is shown above?

- A. Acme
- B. Whitworth
- C. Buttress
- D. Square

33. S in the figure represents

- A. lead.
- B. pitch.
- C. root.
- D. depth.



34. The two metals in the figure below are fastened together using

- A. bolt.
- B. stud.
- C. screw.
- D. weld.

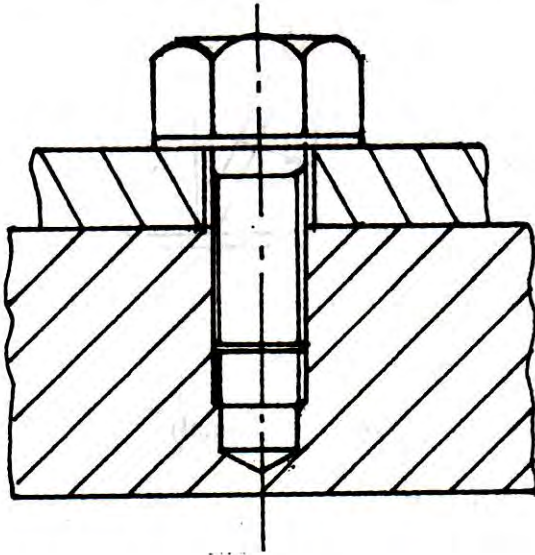

Use the figure below to answer questions 35 and 36.

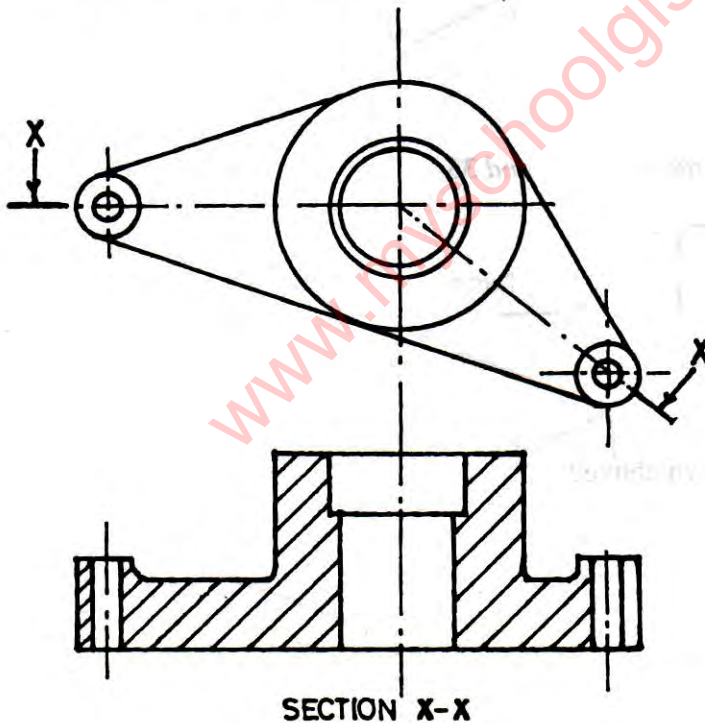

35. What type of section is X-X?

- A. Aligned
- B. Revolved
- C. Removed
- D. Part

36. How many different parts of the object are shown by section X-X?
- A. Five
  - B. Four
  - C. Three
  - D. Two
37. Which of the following machine features are present in the figure below?

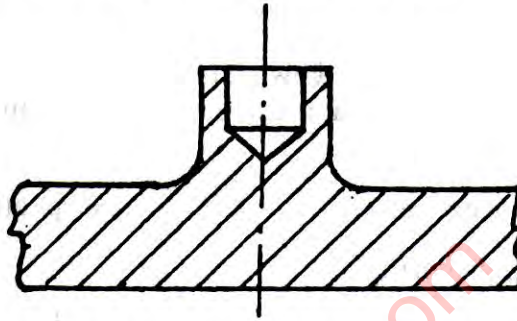

- A. Spot face and chamfer
  - B. Blind hole and fillet
  - C. Counter bored and fillet
  - D. Countersunk and chamfer
38. The profile of a screw thread is constructed using the principle of a/an
- A. helix.
  - B. parabola.
  - C. hyperbola.
  - D. involute.
39. Which of the following is **not** a type of key?
- A. Feather
  - B. Dowel
  - C. Gib
  - D. Woodruff
40. Which of the following is a type of positive locking washer?
- A. Plain
  - B. Spring
  - C. Tab
  - D. Star

**DO NOT TURN OVER THIS PAGE  
UNTIL YOU ARE TOLD TO DO SO.**

**YOU WILL BE PENALIZED SEVERELY IF YOU ARE  
FOUND LOOKING AT THE NEXT PAGE BEFORE  
YOU ARE TOLD TO DO SO.**

SECTION B

1½ hours

[ 60 marks ]

Answer any three questions only from this section.

**NOTE: QUESTION FIVE IS AVAILABLE TO CANDIDATES IN GHANA ONLY.**

Strictly geometrical methods are to be used. Lines that are parallel, perpendicular or inclined at angles of 30°, 45° or 60° to other lines may be drawn without construction lines being shown. All other construction lines **must** be shown clearly. Accuracy and good draughtsmanship are essential.

One A2 (594 × 420 mm) sheet of drawing paper is provided. Both sides may be used. In the bottom right-hand corner of **each** side that is used, write your **name**, **index number** and the **number** of the questions you answered.

All dimensions on the diagrams are in millimetres except otherwise stated.

All questions carry equal marks.

1. A dustbin is made from a 3 mm thick sheet metal. It has a depth 70 mm, top and bottom external diameters are 80 mm and 60 mm respectively. Construct the dustbin in *isometric* view. [ 20 marks ]
2. The major and minor axes of an ellipse are 110 mm and 80 mm respectively. Construct:
  - (a) the ellipse using focal points method;
  - (b) a tangent and a normal to the ellipse at a point P above the major axis and 30 mm from the right hand end of the major axis.
 [ 20 marks ]
3. Three views of a cast bracket are shown below. Construct the bracket in *isometric* view. [ 20 marks ]

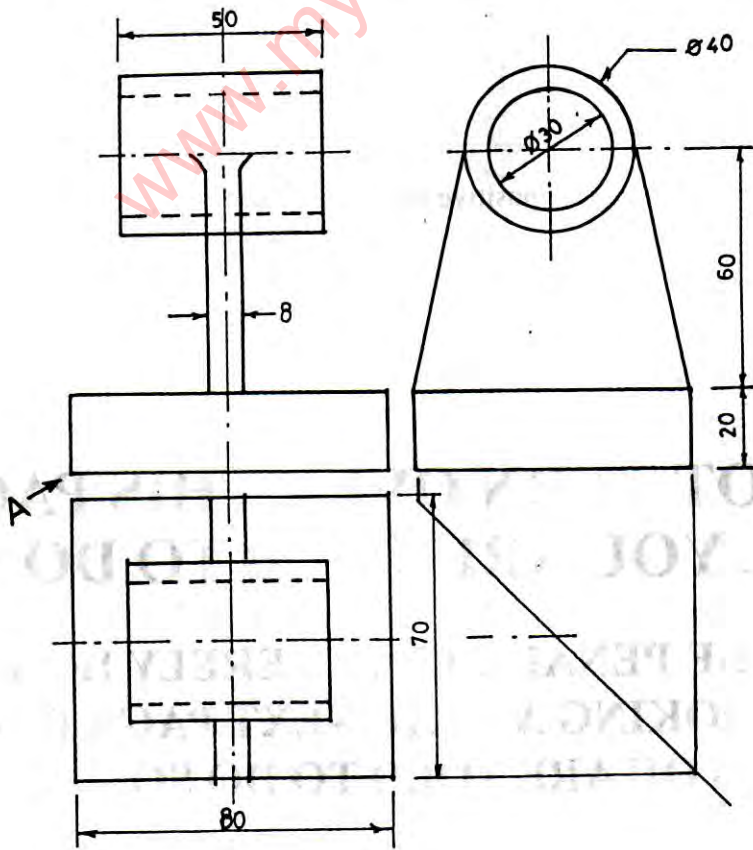



4. A hexagonal based pyramid is cut by a plane P-P as shown below. Draw the

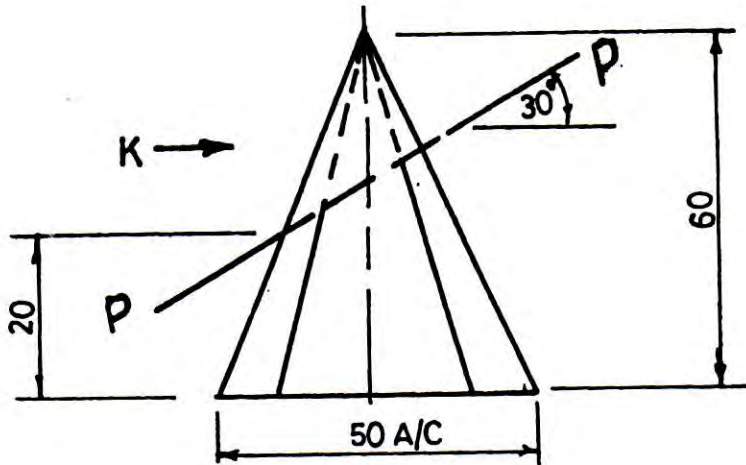

- (a) given elevation;  
 (b) plan;  
 (c) end elevation in the direction of arrow K;  
 (d) true shape of the cut surface.

[ 20 marks ]

QUESTION 5 IS AVAILABLE TO CANDIDATES IN GHANA ONLY.

5. The figure below shows eight non-concurrent co-planer forces acting on a horizontal beam PQ of length 2.4 m.

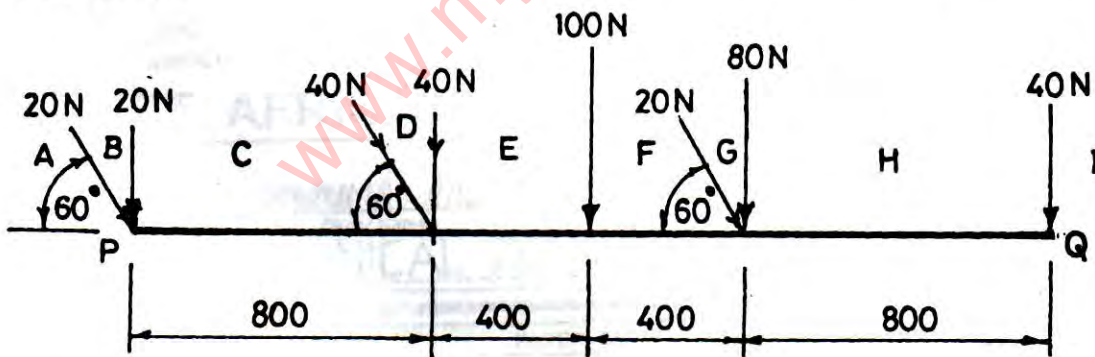

- (a) Draw to a scale of 1:20 (1 mm = 0.02 m) the space diagram;  
 (b) using a scale of 1 mm = 2 N and Bow's Notation indicated (A – I), determine graphically, the  
 (i) magnitude of the resultant of the eight forces;  
 (ii) point of action of the resultant force on the beam from P;  
 (iii) the inclination of the resultant to the horizontal.

[ 20 marks ]