

JSS 2 THIRD TERM MATHEMATICS

SCHEME OF WORK

WEEK TOPIC

1. Angles in a polygons
 - (a) Types of polygons: convex, concave, regular, irregular
 - (b) Sum of interior angles in polygon (number of triangles in a polygon)
 - (c) Sum of exterior angles of a polygon
 2. Angles
 - (a) Horizontal and vertical plane
 - (b) Angles of elevation and depression
 - (c) Relationship between angle of elevation and depression
 - (b) Scale drawing
 - (c) Pythagoras
 3. Bearing and distances
 - (a) The compass directions (major and minor)
 - (b) Types of bearing (Compass, acute-angle, three figure)
 - (c) Converting acute-angle bearing to three figure bearing and vice versa
 - (d) Reciprocal/ back bearing
 - (e) Scale drawing to find bearing and distances
 4. Use of ICT in Mathematics
 - (a) Using computers to solve simple Mathematical calculation (using EXCEL)
 - (b) translation of word problem into Mathematical expression
 - (c) Flow Chart
 5. Computer Application
 - (a) Use of punch cards to store information
 - (b) Writing familiar words in coded form
 6. Construction
 - (a) Construction of special angles (Revision)
 - (b) Constructing triangles
 - (i) 2 sides and included angles (ii) Two angle and a side between them. (iii) all the 3 sides
 - (b) Bisecting angles: bisecting angle 90, 60 and bisect any given angles.
 7. MID-TERM BREAK
 8. Data presentation: (a) Frequency tables (ungrouped and grouped)
 - (b) Construction and interpretation of pie charts
 9. Probability
 - (a) Definition of terms in probability
 - (b) Experimental probability
 - (c) Theoretical probability
 10. Revision
 11. Examination.
-

WEEK 1

TOPIC: Angles in a polygons

- (a) Types of polygons: convex, concave, regular, irregular
- (b) Sum of interior angles in polygon (number of triangles in a polygon)
- (c) Sum of exterior angles of a polygon

POLYGONS AND ITS TYPES

A closed plane figure bounded by straight lines (edges) is called a **polygon**. The number of sides of a polygon determines its names. The table below describes the names of polygons according to the number of their sides:

No. Of sides and angles	Polygon
3	Triangle
4	Quadrilateral
5	Pentagon
6	Hexagon
7	Heptagon
8	Octagon
9	Nonagon
10	Decagon
11	Undecagon / Hendecagon
12	Dodecagon
15	Pentadecagon
20	Icosagon

Types Of Polygons

1. **Convex Polygon:** a convex polygon has all its interior angles pointing outwards. No angle is pointing inwards. Each internal angle of a convex polygon is always less than 180° .

polygon is convex if any line segment joining any two points on it stays inside the polygon itself. Examples of convex polygons are shown below:

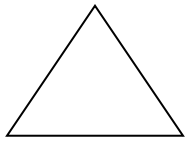

Triangle

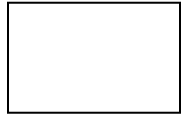

Quadrilateral

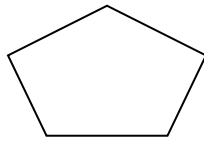

Pentagon

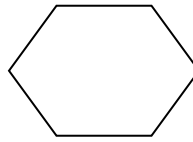

Hexagon

2. **Concave (Re-entrant) Polygon:** If there is any internal angle greater than 180° , the angle points inwards and the polygon becomes concave.

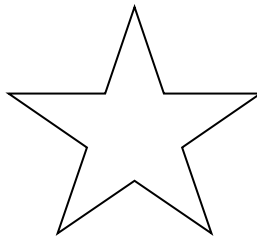

3. **Regular Polygon:** this is a polygon with all its angles the same size and all its sides the same length.
4. **Irregular Polygon:** this is a polygon with at least two of its sides of different length and at least two of its angles unequal.

CLASS ACTIVITY

For each of the polygons drawn below, state whether it is (i) concave or convex (ii) regular or irregular (iii) its name according to the number of sides.

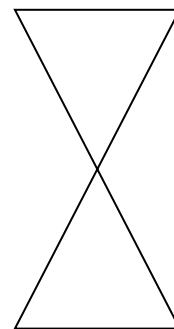
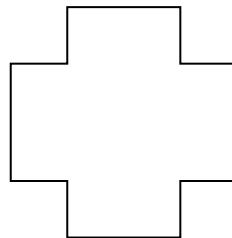
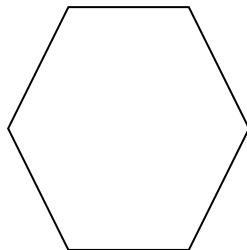
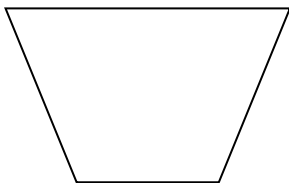

SUM OF INTERIOR ANGLES

The sum of interior angles in a polygon is derived from the number of triangle that can be drawn from the polygon. Consider the diagrams below:

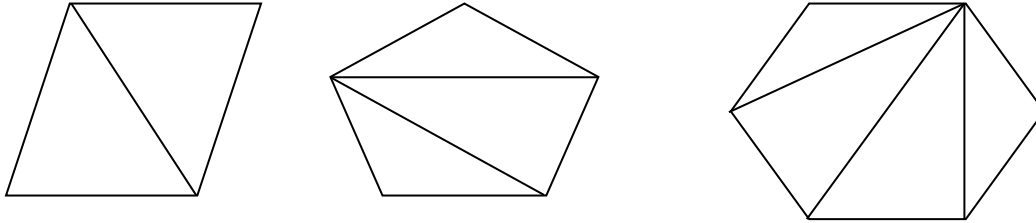

From the above diagrams;

4 sided Quadrilateral has 2 triangles, 5 sided Pentagon has 3 triangles and 6 sided hexagon has 4 triangles. We can therefore say that a n-sided polygon has $n - 2$ triangles.

Since sum of angles in a triangle is 180° ;

A polygon with 4 sides having 2 triangles will have $2 \times 180^\circ = 360^\circ$

5 sided polygon having 3 triangles will have $3 \times 180^\circ = 540^\circ$

6 sided polygon having 4 triangles will have $4 \times 180^\circ = 720^\circ$

In general, the sum of the interior angles of any convex n-gon (polygon with n sides) is given by:

$$\text{Sum of interior angles} = (n-2) \times 180^\circ = (n-2) \times 2 \times 90$$

$$\text{Or Sum of interior angles} = (2n - 4) \times 90^\circ$$

$$\text{Or Sum of interior angles} = (2n - 4) \text{ Right angles}$$

For a regular polygon that has all its sides and angles equal, the size of each interior angle will be the average of the sum of all interior angles

Therefore each interior angle for a regular convex polygon

$$\text{Each interior angle} = \frac{\text{Sum of interior angles}}{\text{Number of sides}} = \frac{(n-2) \times 180^\circ}{n}$$

EXAMPLE – 1: What is the sum of the interior angles of a pentagon?

Solution

A pentagon has five sides, that is, $n = 5$.

$$\begin{aligned}\text{Therefore, sum of interior angles} &= (n - 2) \times 180^\circ \\ &= (5 - 2) \times 180^\circ \\ &= 3 \times 180^\circ = 540^\circ\end{aligned}$$

EXAMPLE – 2: Calculate the size of each interior angle of a regular heptagon.

Solution

A regular heptagon has 7 equal sides, that is, $n = 7$.

$$\begin{aligned}\text{Each interior angle} &= \frac{\text{Sum of interior angles}}{\text{Number of sides}} = \frac{(n-2) \times 180^\circ}{n} \\ &= \frac{(7-2) \times 180^\circ}{7} = \frac{5 \times 180^\circ}{7} \\ &= \frac{900^\circ}{7} = 128\frac{5}{7}\end{aligned}$$

Class Activity

- (1) What is the sum of interior angles of a: (a) hexagon (b) nonagon
- (2) The sum of six of the interior angles of a nonagon is 920° . The other three angles are all equal. Find the size of each of the other three angles.
- (3) If the angles of a quadrilateral are x , $2x$ and $3x$, what is the value of x ? Calculate the size of the largest angle.

Sum of Exterior Angles

Sum of exterior angles in any Polygon = 360°

EXAMPLE – 1: The sum of the interior angles of a regular polygon is 10 right angles.

- (i) How many sides has the polygon?

- (ii) What is the sum of the exterior angles of the polygon?
- (iii) Calculate the size of each exterior angle of the polygon.

Solution:

- (i) Sum of interior angles = $(n - 2) \times 180^\circ = (n - 2) \times 2 \times 90^\circ$
Sum of interior angles = $(2n - 4) \times 90^\circ$

Sum of interior angles = $(2n - 4)$ right angles

$$2n - 4 = 10$$

$$2n = 10 + 4$$

s

- (ii) Sum of exterior angles = 360°
- (iii) Each exterior angle = $\frac{\text{Sum of exterior angles}}{\text{Number of sides}}$

$$= \frac{360^\circ}{7}$$

$$= 51 \frac{3^\circ}{7}$$

Class Activity

- 1) Calculate the size of each exterior angle in a regular: (a) octagon (b) decagon
- 2) Is the sum of exterior angles of a triangle equal to the sum of exterior angles of an Icosagon?

ASSIGNMENT:

Find the measure of one interior angle, one exterior angle, and the interior angle sum for each polygon. Round your answer to the nearest tenth if necessary.

1)

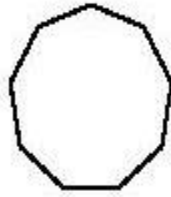

Interior Angle: _____
Exterior Angle: _____
Interior Angle Sum: _____

2)

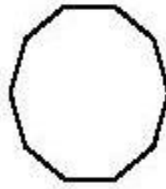

Interior Angle: _____
Exterior Angle: _____
Interior Angle Sum: _____

3)

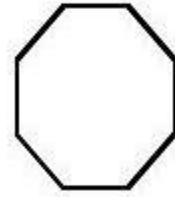

Interior Angle: _____
Exterior Angle: _____
Interior Angle Sum: _____

4)

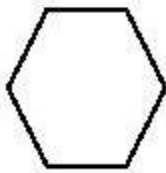

Interior Angle: _____
Exterior Angle: _____
Interior Angle Sum: _____

5)

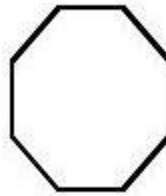

Interior Angle: _____
Exterior Angle: _____
Interior Angle Sum: _____

6)

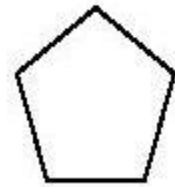

Interior Angle: _____
Exterior Angle: _____
Interior Angle Sum: _____

7)

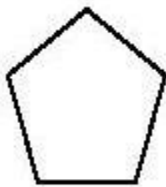

Interior Angle: _____
Exterior Angle: _____
Interior Angle Sum: _____

8)

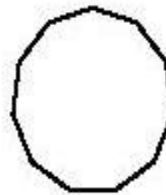

Interior Angle: _____
Exterior Angle: _____
Interior Angle Sum: _____

9)

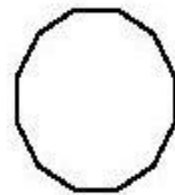

Interior Angle: _____
Exterior Angle: _____
Interior Angle Sum: _____

10)

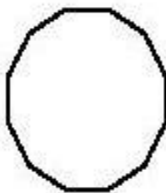

Interior Angle: _____
Exterior Angle: _____
Interior Angle Sum: _____

11)

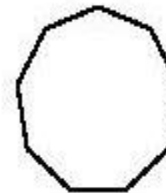

Interior Angle: _____
Exterior Angle: _____
Interior Angle Sum: _____

12)

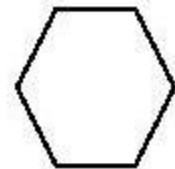

Interior Angle: _____
Exterior Angle: _____
Interior Angle Sum: _____

PRACTICE QUESTIONS:

Interior Angle

ES1

Example:



$$\begin{aligned} \text{Interior angle} &= \frac{\text{sum of interior angles}}{\text{Number of sides}} \\ &= \frac{720^\circ}{6} \\ &= 120^\circ \end{aligned}$$

Find the interior angle for each regular polygon. Round the answer to nearest tenths if necessary.

1)



Sum of the interior angles –

Each interior angle –

2)



Sum of the interior angles –

Each interior angle –

3)



Sum of the interior angles –

Each interior angle –

4)

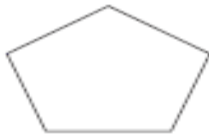

Sum of the interior angles –

Each interior angle –

5)



Sum of the interior angles –

Each interior angle –

6)



Sum of the interior angles –

Each interior angle –

7)



Sum of the interior angles –

Each interior angle –

8)

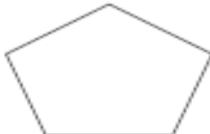

Sum of the interior angles –

Each interior angle –

9)



Sum of the interior angles –

Each interior angle –

WEEK 2

TOPIC: ANGLES OF ELEVATION AND DEPRESSION

Contents:

- (a) Horizontal and vertical plane.
- (b) Angles of elevation and depression.
- (c) Relationship between angle of elevation and depression.
- (d) Measuring angles of elevation and depression.
- (d) Scale drawing.

Horizontal and Vertical Plane

An horizontal plane *lies* (flat) in the same position as the ground while a vertical plane *stand* like a straight wall.

Angles of Elevation and Depression

Angle of Elevation: the angle that an observer would raise his or her line of sight above a horizontal line in order to see an object. The angle of elevation is the angle between the horizontal and the observer's line of sight.

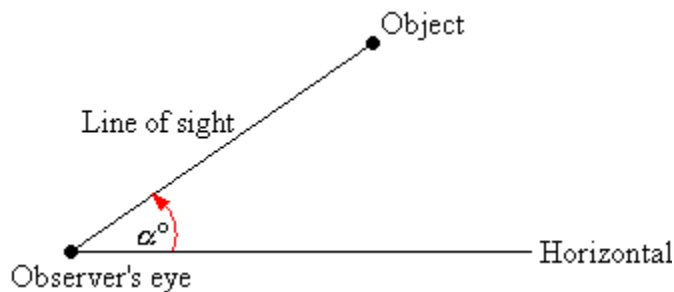

In the diagram above, the angle of elevation of the object from the observer is α° .

Angle of Depression: If the object is below the level of the observer, then the angle between the horizontal and the observer's line of sight is called the angle of depression. If an observer were up above and needed to look down, the angle of depression would be the angle that the person would need to lower his or her line of sight.

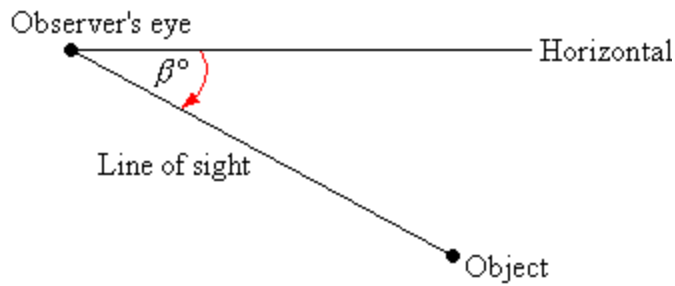

In the diagram above, the angle of depression of the object from the observer is β° .

MEASURING ANGLES OF ELEVATION AND DEPRESSION

Angles of elevation and depression can be measured with a simple instrument called Clinometers. Simple Clinometers is made from a chalk-board protractor in which a plumb-line hangs from the center of the protractor. The angle that the plumb-line makes with the 90° vertical axes when the Clinometers is placed in the observer's direction is the angle of elevation or depression.



In the figure above, a plumb-line hangs from the center of the protractor at A. The observer sights an object along the line BAC. The angle of elevation e° is the angle between AO and the plumb-line. The size of e° can be read from the scale. Notice that e° increases from 0° at O to 90° at B.

NOTE: The teacher should make simple clinometers using a chalk-board protractor and plumb-line.

Class Activity:

Carry out the following activities using a tape and clinometers:

- 1) Stand at a point Y on level ground, where the top of the wall in your class has an angle of elevation of 45°
- 2) Find the distance from Y to the base of the wall in your class. Record the height of the wall.

RELATIONSHIP BETWEEN ANGLE OF ELEVATION AND DEPRESSION

In other words, as shown in the diagrams below, the angle formed with the horizontal when an observer looks up is called angle of elevation whereas, the angle formed with the horizontal when an observer looks down is called angle of depression.



There is a connection between angle of elevation and angle of depression. For example, the angle of elevation of Y from X is the same as the angle of depression of X from Y. Therefore angles of elevation and depression are alternate angles and are therefore equal in a given situation.

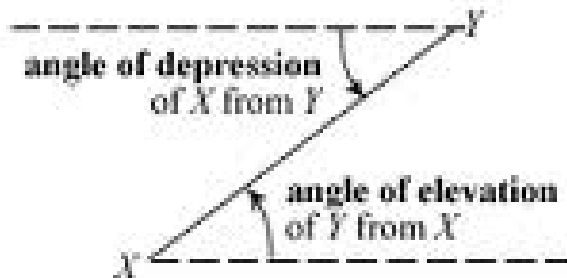

SCALE DRAWING

Example

Use scale drawing to answer the questions that follows the diagram:

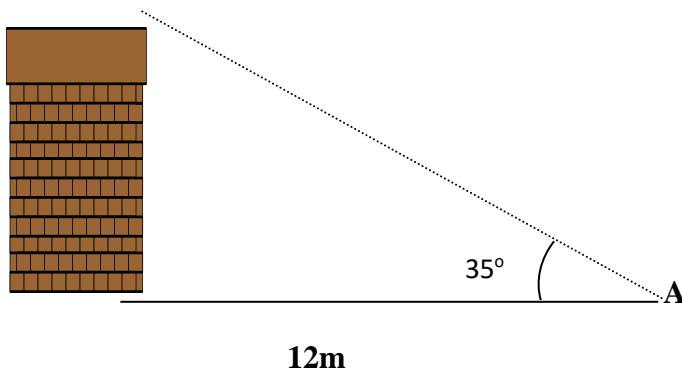

- What is the angle of depression (θ) of the top of the building from the observer at point A
- Find the height of the building in the figure above.

STEP 1: draw a sketch of the figure in form of a right-angled triangle

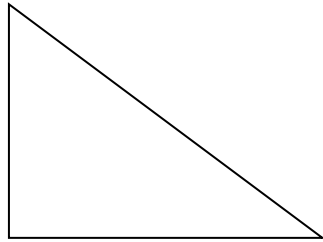

STEP 2: Choose an appropriate scale, considering the measurements on the given lengths in the original diagram. From 12m, a scale of 1cm represent 2m can be used to draw 12m as 6cm.

STEP 3: Draw the appropriate diagram, measure and mark the given angle.

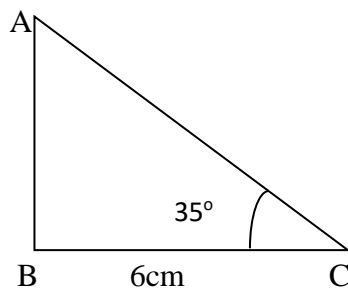

STEP 4: Measure length AB in cm then convert it back to m to get the height of the building

NOTE: Teachers should exemplify this on the board, using the relevant instruments.

Class Activity

Find the (i) The angle of elevation in the diagram.

(ii) Distance between point A and B on level ground.

NB: Using scale drawing.

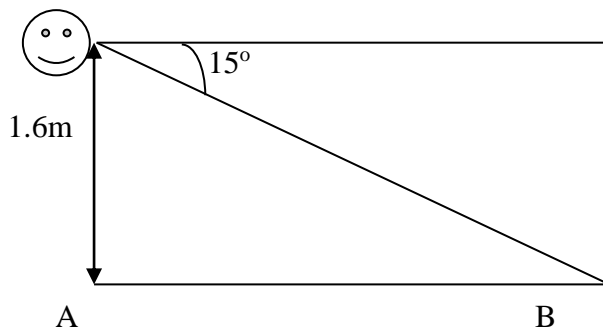

In each of the following illustrations, identify whether $\angle A$ is an angle of elevation or an angle of depression.

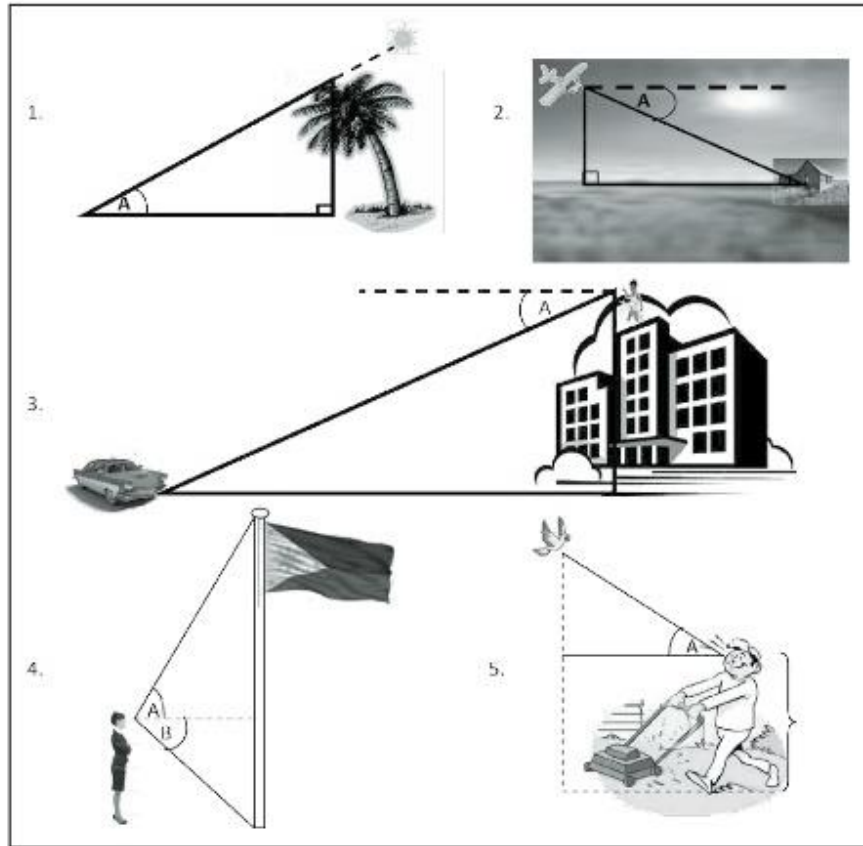





2. When the elevation of the sun is 33° , a student has a shadow of 2.9m long. Make a scale drawing and find the height of the student to the nearest 5cm.

PRACTICE QUESTIONS

1.

In the following figures, identify the segment that represents the line of sight, and identify the angles (if any) that represent the angle of elevation or angle of depression.

Figure	Angle of Elevation	Angle of Depression	Line of Sight
			
			
			
			
			

2. (a) What is the angle between the minute-hand and hour-hand of a clock at 3 O'clock.
 (b) Find the angle between the hands of a clock at 7 O'clock.
3. From the top of a tower 14m high, the angle of depression of a student is 32° . Make a scale drawing and find the distance of the student from the foot of the tower to the nearest $\frac{1}{2}$ m.

WEEK 3

TOPIC: BEARING AND DISTANCES.

- (a) The compass directions (major and minor)
- (b) Types of bearing (Compass, acute-angle, three figure)
- (c) Converting acute-angle bearing to three figure bearing and vice versa
- (d) Reciprocal/ Back bearing
- (e) Scale drawing to find bearing and distances

THE COMPASS DIRECTIONS

Major Compass/Cardinal Directions

There are four major directions used to describe locations. These cardinal directions are:

North (N) South(S), East (E) West (W).

The four main directions, North, South, East and West, divide the angle at a point (360°), into four equal parts and each is 90° or a right angle.

Minor Cardinal Directions

Other minor cardinal directions are those that lie in the midpoints as follows:

North and East called North-East (NE)

South and West called South-West (SW)

South and East called South-East (SE)

North and West called North-West (NW).

These minor cardinal directions subdivide each right angle into two equal parts such that the angle between each major cardinal and minor direction is 45° . The eight cardinal points are illustrated below:

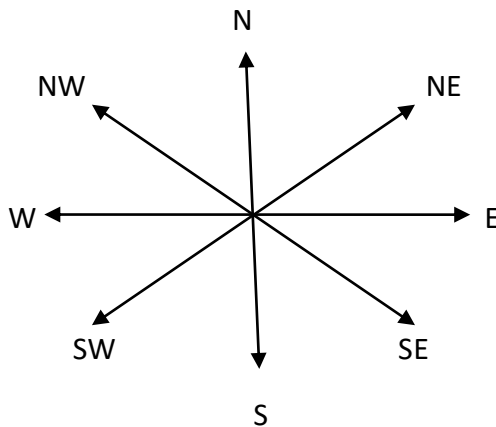

BEARINGS AND ITS TYPES

In simple terms, **bearing** is the direction of one point with respect to a given point.

If a line which points due North of a compass is fixed, the direction of any other line on the surface of the earth is given as the angle which it makes with the North-pointing line, this angle is called bearing. In particular, we must note that the bearing is measured from the line due North in a clockwise direction. Since bearings involve mainly finding directions, we use a compass to find them.

The Compass and Compass/ Directional Bearing

The Compass is an instrument used in finding directions. It is also used in erecting a wind-vane in the correct position. A wind vane is an instrument used in detecting the direction of the wind. It can, therefore be used in place of a compass to determine cardinal directions.

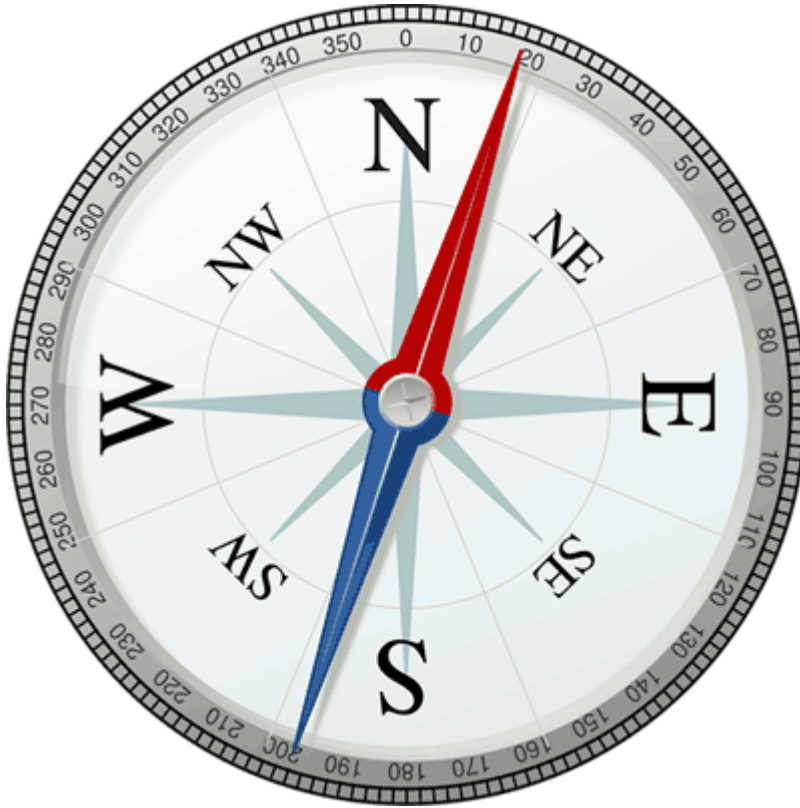

Compass bearing is the direction of one point with respect to a given point given in terms of the major or minor cardinal direction of the relative point.

Consider the points X and Y in the diagram below:

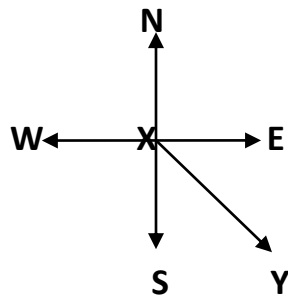

The Acute Angle or Simple Bearing

This method involves using the acute angle which the line XY makes with the North or South (in the diagram above, the South Pole is appropriate) direction at X, Eastwards or Westwards. For

example, in the diagram below, the bearing of Y from X is written as S 30° E or (or South 30° Eastwards) and is called the acute-angle bearing of Y from X.

In general, acute angle bearings are measured in relation to the North or South Pole and must therefore be greater than 0° but less than 90° as its name implies. If an angle related to the East or West pole is given, its complementary angle is used to give the acute-angle bearing.

The Three-figure or Surveyor's Bearing

This method involves reading on the compass, the angle which the line XY makes with the North direction. This angle is the bearing of the object Y from the reference point X, and it is called the surveyor's bearing of Y from X. The surveyor's bearing is written with three digits known as **three-figure bearings**. When the angle is between 0° and 90° inclusive, say 7°, the bearing is written as 007°, that is, two zeros are added before the angle. Suppose the angle is 55°, we write it as 055°.

Directional versus Three-figure versus Acute Angle Bearing

Examples:

1.

Directional	Three-figure Bearing	Acute-Angle Bearing
North	000°/ 360°	-
North East	045°	N45°E
East	090°	-
South East	135°	S45°E
South	180°	-
South West	225°	S45°W
West	270°	-
North West	315°	N45°W

2. Directional/ Compass = NE

The three-figure bearing = 037°

Acute Angle bearing = N37°E

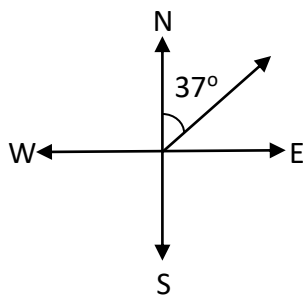

3. The three-figure bearing = 117°

The Acute-angle bearing = S63°E

The compass/directional bearing = SE

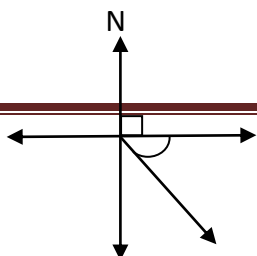

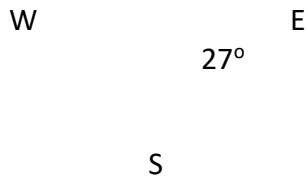

4. The three-figure bearing = 246°
 The Acute-angle bearing = $S66^\circ W$
 The compass/directional bearing = SW

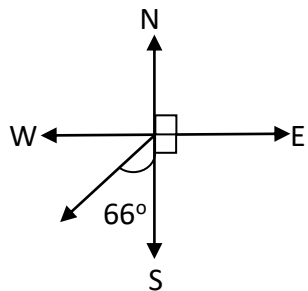

5. The three-figure bearing = 344°
 The Acute-angle bearing = $N16^\circ W$
 The compass/directional bearing = NW

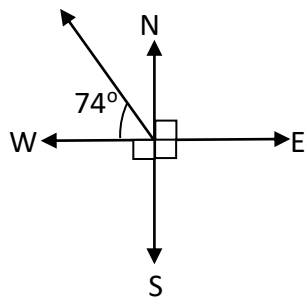

6. The table below shows the angles when the turning is clockwise from the South direction to the other cardinal directions

Direction	N	E	W	NE	NW	SE	SW
Clockwise Turning from South	180°	270°	90°	225°	135°	315°	45°

CLASS ACTIVITY

1. Complete a table showing the angles when the turning is clockwise from the North-East direction to the other cardinal directions.

Direction	N	S	E	W	NW	SE	SW
Clockwise Turning from South	315°			225°			

2. The three-figure bearing =
 The Acute-angle bearing =
 The compass/directional bearing =

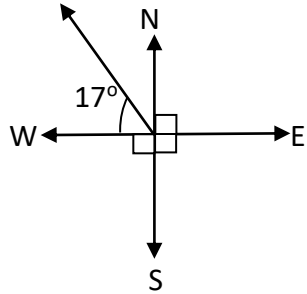

3. Directional/ Compass =
 The three-figure bearing =
 Acute Angle bearing =

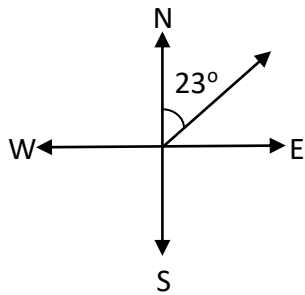

4. The three-figure bearing =
 The Acute-angle bearing =
 The compass/directional bearing =

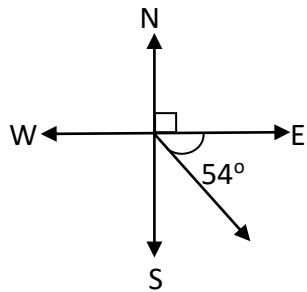

5. The three-figure bearing =
 The Acute-angle bearing =
 The compass/directional bearing =

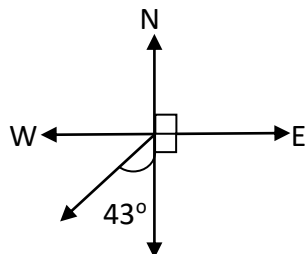

S

6. The three-figure bearing = 344°
The Acute-angle bearing = $N16^\circ W$
The compass/directional bearing = NW

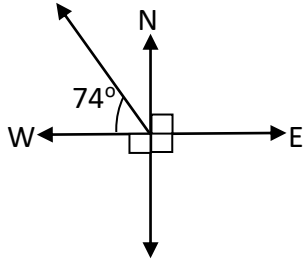

RECIPROCAL/ BACK BEARING

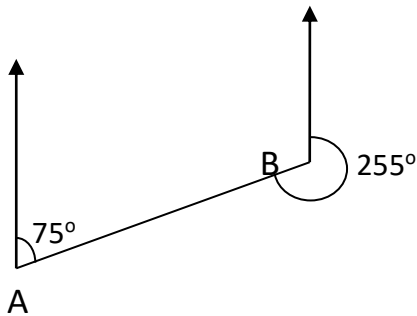

The bearing of B from A is 075° , while the bearing of A from B is 255° . 255° is called the back/ reciprocal bearing of 075° .

In general, if the bearing is less than 180° we add 180° to get the back bearing and if the bearing is greater than 180° we subtract 180° .

Example

Find the bearing whose reciprocal/ back bearing is?

- (1) 033°
 33° is less than 180°
So we add 180° to 33°
 $180^\circ + 33^\circ = 218^\circ$
So the back bearing of 033° is 218°
- (2) 220°
 220° is greater than 180°
So we subtract 180° from 220°
 $220^\circ - 180^\circ = 40^\circ$
So the back bearing of 220° is 40°

Class Activity

Find the bearing whose reciprocal/ back bearing is?

1) 24°

2) 135°

3) 260°

4) 195°

SCALE DRAWING

Example

Ibadan is 116km on a bearing 027° from Lagos. How far north of Lagos is Ibadan? How far west of Ibadan is Lagos?

Solution

Make a scale drawing of the data

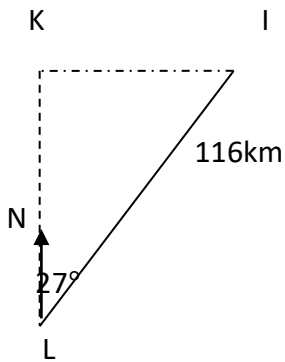

Scale: 1cm to 20km

K is the point which is due north of Lagos and due west of Ibadan. LK represents the distance that Ibadan is north of Lagos.

By measurement, $LK \approx 5.2\text{cm}$

The true distance $LK \approx 5.2 \times 20\text{km}$

$$= 104\text{km}$$

IK represents the distance that Lagos is west of Ibadan.

By measurement, $IK \approx 2.6\text{cm}$

The true distance $IK \approx 2.6 \times 20\text{km}$

$$= 52\text{km}$$

Thus Ibadan is approximately 104km north of Lagos and Lagos is approximately 52km west of Ibadan.

Class Activity

- 1) A boy cycles south for a distance of 4km. he then cycles 7km on a bearing 036o. make a scale drawing of his journey. Hence find how far he is from his starting point. (a) East (b) North.

ASSIGNMENT:

1. Draw an accurate diagram for each of the following bearings
 - (i) An aircraft flying on a bearing of 075° .
 - (ii) A submarine travelling on a bearing of 150° .
 - (iii) A rocket travelling on a bearing of 200° .
 - (iv) A car travelling on a bearing of 048° .
 - (v) A helicopter flying on a bearing of 310° .
2. Directional/ Compass =
The three-figure bearing =
Acute Angle bearing =

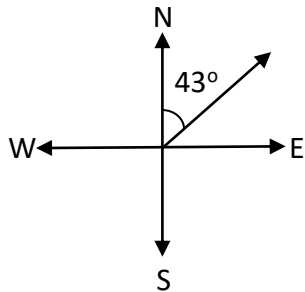

3. The three-figure bearing =
The Acute-angle bearing =
The compass/directional bearing =

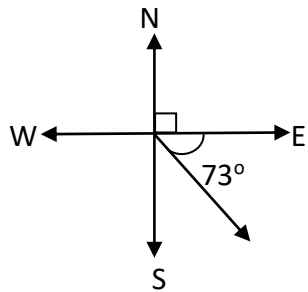

4. The three-figure bearing =
The Acute-angle bearing =
The compass/directional bearing =

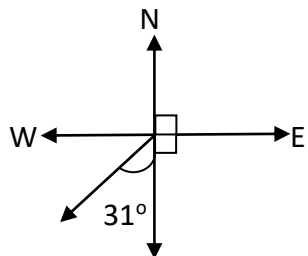

S

5. The three-figure bearing =
The Acute-angle bearing =
The compass/directional bearing =

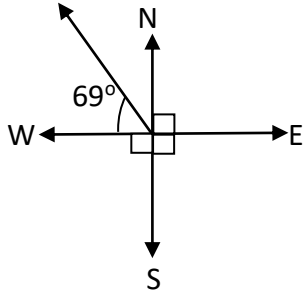

6. A woman travels 3km south, then 4km south-west and finally 5km west. Make a scale drawing to find the distance and bearing from her starting point.

PRACTICE QUESTIONS

- Convert these three figure bearings to equivalent acute –angle bearings
(a) 060° (b) 242° (c) 117° (d) 343°
- Find the bearing whose reciprocal/ back bearing is?
(a) 24° (b) 135° (c) 260° (d) 195°
- Convert these acute-angle bearings to equivalent acute –angle bearings
(a) $S6^\circ W$ (b) $N78^\circ E$ (c) $N53^\circ W$ (d) $S60^\circ E$

Angle properties and bearings

1. Each diagram shows the bearing of B from A. Calculate the bearing of A from B.

a)

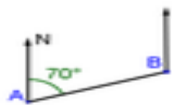

b)



c)

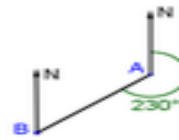

2. Determine the shaded angle ABC in each diagram. You do not need a scale drawing or protractor.

a)

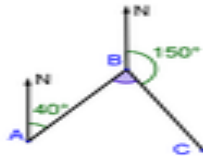

b)

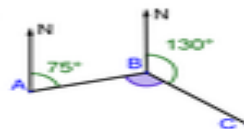

c)

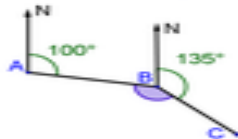

d)

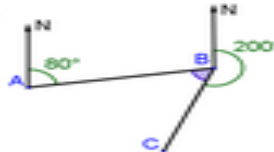

3. In each diagram, a boat sails from A to B, then turns through the marked angle and sails to C. When the boat is at B, calculate:

- i. the bearing of A from B
- ii. the bearing of C from B

a)



b)

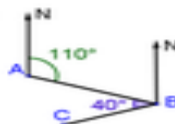

WEEK 4

TOPIC: USE OF ICT IN MATHEMATICS

CONTENT:

- (a) Using computers to solve simple Mathematical calculation (using EXCEL)
- (b) translation of word problem into Mathematical expression
- (c) Flow Chart

DEFINITION OF COMPUTER AND ICT

Computer is an electronic device that aids computation, storage of information, processing of data, etc.

ICT is an abbreviation for Information and Communication Technology. It is a modern way of processing and distributing data using computer hardware and software, telecommunications, and digital electronics. The computer is configured based on the binary number system only, which is **0** and **1**.

USE OF COMPUTER FOR MATHEMATICS IN ICT

There are many specific forms in which ICT may be used in Mathematics teaching and learning. These include calculators, search engines (Google), presentation packages (PowerPoint), drill and practice software, spreadsheets (MS-Excel), databases and online interactive resources.

With the introduction of Information Technology (IT), doing simple Mathematical calculations on computer is now easier and interesting. The software written on mathematics that make calculations easier are called Mathematics Compact Discs. Examples of mathematics software are Encarta Premium, Encarta Kids, Equation solver, Geo-Gebra, triangle solver, etc. Other ICT gadgets or materials that are useful in the teaching and learning of mathematics are: Mathematics tools, power point, Encarta dictionary, calculator, search engines, interactive board, etc.

NOTE: Teachers should teach the students how to use the available mathematics software to calculate simple mathematical problems. Special attention should be given to how to MS-Excel to perform simple calculations.

MS-EXCEL

MS-Excel is an example of a Spreadsheet application, developed and designed for accounting purposes such as budgeting, general ledger, journals, inventory control, payroll, cashbooks, etc.

In the MS-Excel window, on the menu bar click *FORMULA*. *FORMULA* is a sequence of instructions used for calculations. It is used to perform a certain function and could be a series of letters, numbers or symbols that represents a rule or law.

To start a formula, you the equal sign (=), followed by the needed cell or cells. A cell is named with respect to its ColumnRow title e.g.: D5 represents column D row 5.

To calculate 'total', you could use;

(1) Cell by cell formular: allows us to calculate by adding the cells as follows:

= D2 + E2 + F2 + G2 + H2, then press 'ENTER'

(2) Function Name: using 'SUM' under formula. 'SUM' is used to add a set of numbers as follows; = SUM (D2 : H2), then press 'ENTER'

To calculate 'average', use any of these;

(1) Cell by cell formular: allows us to calculate by adding the cells then dividing by the number of values as follows:

(= D2 + E2 + F2 + G2 + H2) / 5, then press 'ENTER'

(2) Function Name: using 'SUM' under formula then divide by the number of values as follows; = SUM (D2 : H2)/ 5, then press 'ENTER'

(3) Function Name: using 'AVERAGE' under formula. 'AVERAGE' is used to find the mean of a set of numbers as follows; = AVERAGE (D2 : H2), then press 'ENTER'

To calculate 'percentage', you could use;

(1) Cell by cell formular: allows us to calculate by naming the required cells as follows:

= (D2/ (D2 + E2 + F2 + G2 + H2)) × 100, then press 'ENTER'

- (2) Function Name: state the cell of the value whose average you want to find.
Using 'SUM' under formula find the average as follows; $= (E2/SUM (D2 : H2)) \times 100$, then press 'ENTER'

Teacher should direct students on how to use other formula elements to carry out task.

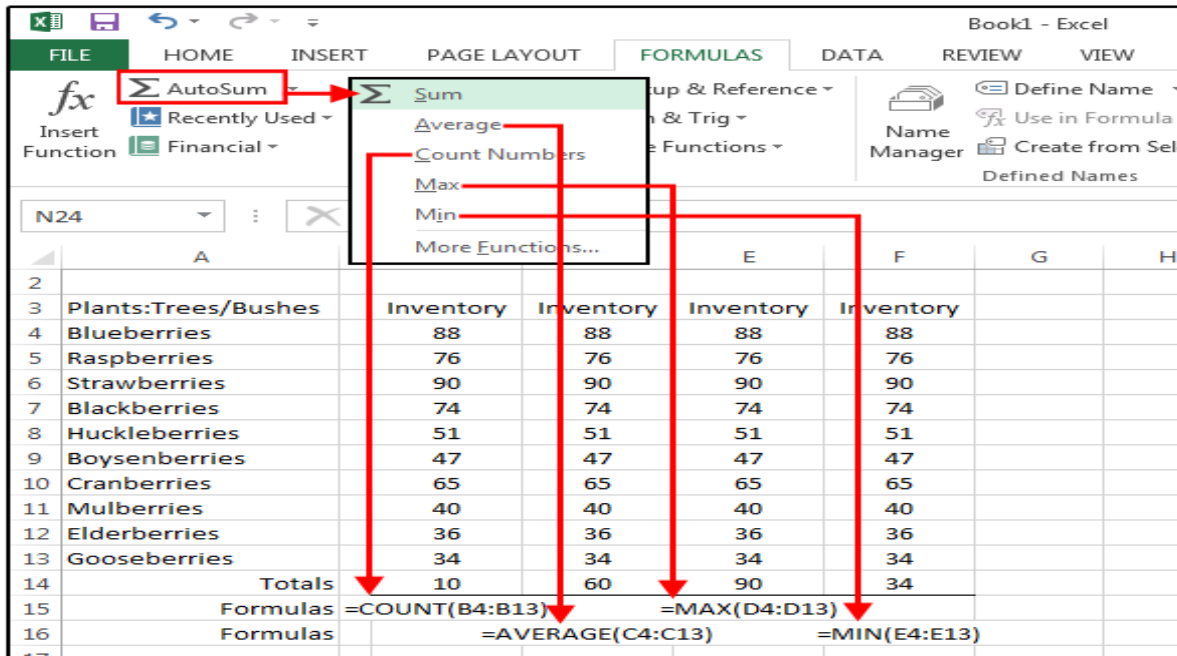

Class Activity:

- Define
 - Computer
 - Information Communication Technology.
- What is Microsoft Excel and what are the operations that can be carried with this software?
- Using MS-Excel, enter 12, 31, 24, 74, 38, 94, 58, 88 into different cells. Obtain the (i) sum (ii) average (iii) percentage (iv) minimum (v) maximum of those numbers.

TRANSLATING WORD PROBLEMS INTO NUMERICAL EXPRESSIONS.

The following terms are commonly used in words expressions.

- **SUM:** The sum of two or more numbers is the result obtained when they are added together.

- **DIFFERENCE:** The *difference* between two numbers is the result obtained when one of the numbers is subtracted from the other.
- **POSITIVE DIFFERENCE:** This implies larger number *minus* smaller number.
- **NEGATIVE DIFFERENCE:** This implies smaller number minus larger number.

NOTE: When the nature of the difference required is not stated, we consider the *positive difference*.

- **PRODUCT:** When two or more numbers are multiplied together, the result obtained is known as the *product* of the numbers.
- **QUOTIENT:** The *quotient* of two numbers is the result obtained by dividing one number by another.

Examples:

Translate the following word problems into numerical expressions.

1. From the sum of 78 and 129 subtract 264

Solution:

$$(78 + 129) - 264$$

2. What must be multiplied by 0.75 to obtain 6?

Solution:

$$\text{Let the number be } x \Rightarrow x(0.75) = 6$$

3. Add 18 to the negative difference between 56 and 45.

Solution:

$$(45 - 56) + 18$$

Class Activity:

Translate the following word problems into numerical expressions.

1. When a number is trebled and five times the number is subtracted, the result is 3.7
2. The sum of three consecutive numbers is 108.





FLOW CHART

A flow chart operates with respect to an *algorithm*. A collection of specific instructions involved in solving any mathematical problem is known algorithm. When an algorithm is presented in a diagrammatic form is known as flow chart.

In other words, a flow chart is a diagram consisting of a sequence of **shapes** that shows the logical sequence of the operations which must take place in order to reach the solution to a mathematical problem. Each shape contains one *instruction*. An *arrow* connects the shapes. The arrows tell us which instruction to

follow first, which comes second and so on. When a process is repeated in a flow chart, **loops** are used. Flow chart is basically use for solving everyday arithmetic problems and other complicated operations are reduced to small steps.

The table below shows the geometrical symbols used in flow charting.

Shape /symbol	Name	Function
	Oval	Terminal symbol
	Rectangle	Process symbol
	Parallelogram	Input/ Output symbol
	Diamond	Decision symbol
	Small circle	Connector symbol

Example:

Calculate the average of 4, 7, 9, 5, 3, 7, 7, 6, 8, 5 using flow chart.

Solution:

Step 1: Input the given values

Step 2: Sum up the scores.

Step 3: Divide sum by 10 (the number of values).

Step 4: Give the result (average).

The flow chart:

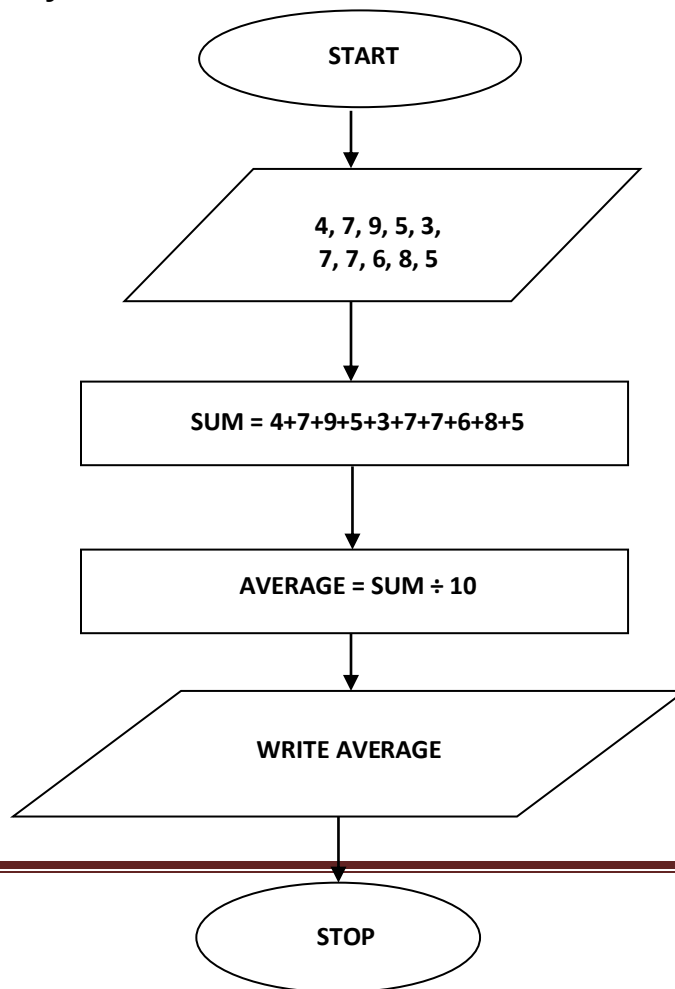

Class Activity:

1. Draw a flow chart to show what happens when you:
 - a. Visit a library
 - b. Cross a road
 - c. Look for a word in the dictionary
 - d. When you bake cake
2. Draw a flow chart to solve this equation: $2 + x = 7$

Assignment

1. MS-Excel: enter five numbers of your choice into different cells. Obtain the (i) average (ii) percentage (iii) maximum of those numbers.
The MS-Excel window of your solution should be printed and submitted to your teacher.
2. Translate this word problem into numerical expressions;
If a certain number is doubled and 7 subtracted, the result is 23.
3. Draw a flow chart to show what happens when you:
 - (i) Go to the health bay
 - (ii) Have your lunch
4. (i) Calculate the sum of 7, 5, 3, 7, 6, 8 using a flow chart.
(iii) Draw a flow chart to solve this equation: $2 + x = 7$

Practice questions

1. Use MS-Excel to calculate the average age of all students in your class.
2. (i) Divide the sum of 12 and -4 by the sum of -12 and 4.
(iii) The difference between a certain number and -8 is 15.
3. Draw a flow chart to show what happens when you:
 - (a) Look for a word in the dictionary.
 - (b) When you bake cake
4. (i) Draw a flow chart to solve this equation: $2 + x = 7$
(ii) Calculate the average age of all the students in your class.

TOPIC: COMPUTER APPLICATION

CONTENT:

- Use of punch cards to store information
- Writing familiar words in coded form

USE OF PUNCH CARDS TO STORE INFORMATION

The punch card is a practical application of binary numbers in the development of Information Technology. It is made up of hard paper. The punch cards were used at the onset of Computer Development to store information in form of data bits in columns. The mode of storage used a perforated hole to represent 0 and a cut out slot to represent 1. Examples include:

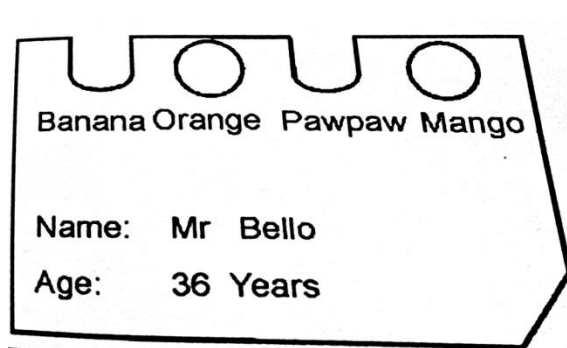

Figure 1

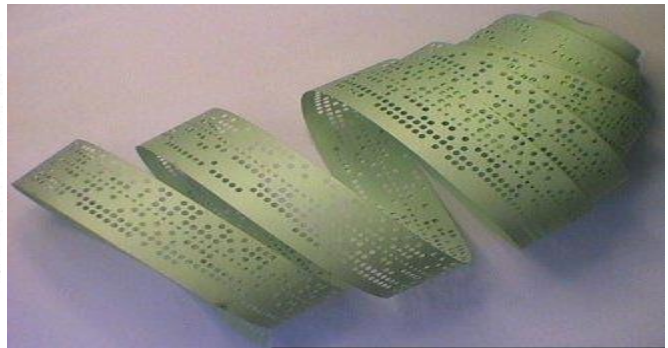

Figure 2

Figure 1 shows the storage of information about a man named Mr. Bello who is 36 years old.

Figure 2 shows a punch tape which is an improvement on the punch cards as it can store a greater amount of information. It has 8 columns with each column having 0s (holes) and 1s (cut-outs). The first three columns are used for specific instructions while the last 5 are used for general instructions.

Class Activity

1. What is the major difference between a punch card and paper tapes.
2. Before the advent of punch cards and tapes, what do you think were used to store information?

WRITING FAMILIAR WORDS IN CODED FORM

Recall the conversion of numbers in base 10 to binary, those binary conversions can be used to store numeric information as follows:

Base 10	0	1	2	3	4	5	6	7
Binary	000	001	010	011	100	101	110	111

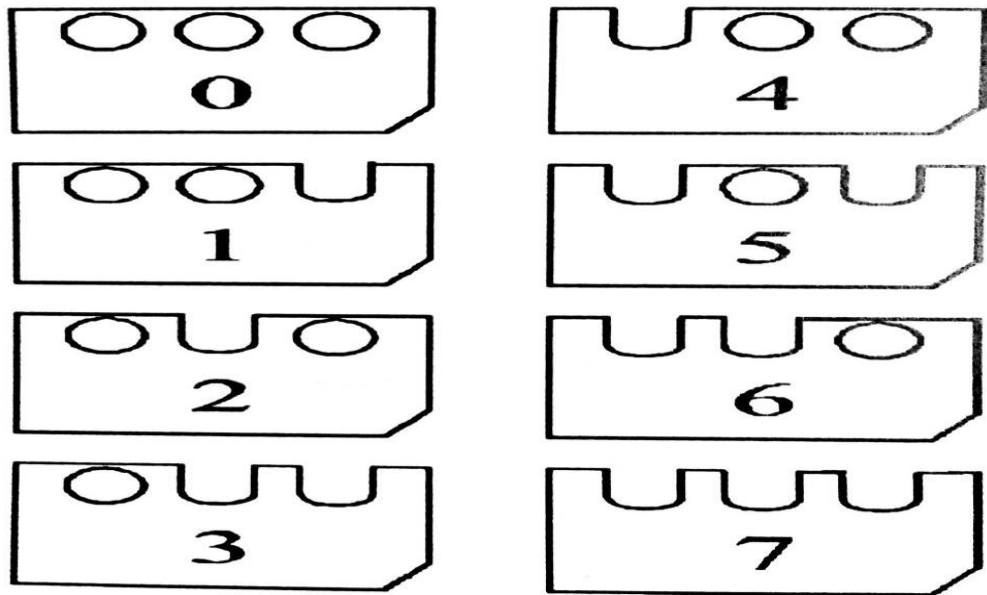

To store words, each letter of the alphabet is given a numeric code of numbers from 1 – 26. Each numeric code can then be converted to binary codes as shown below:

LETTERS	DECIMAL CODE	BINARY CODE
A	1	00001
B	2	00010
C	3	00011
D	4	00100
E	5	00101
F	6	00110
G	7	00111
H	8	01000
I	9	01001
J	10	01010
K	11	01011
L	12	01100
M	13	01101
N	14	01110
O	15	01111
P	16	10000
Q	17	10001
R	18	10010
S	19	10011

T	20	10100
U	21	10101
V	22	10110
W	23	10111
X	24	11000
Y	25	11001
Z	26	11010

Examples:

1.

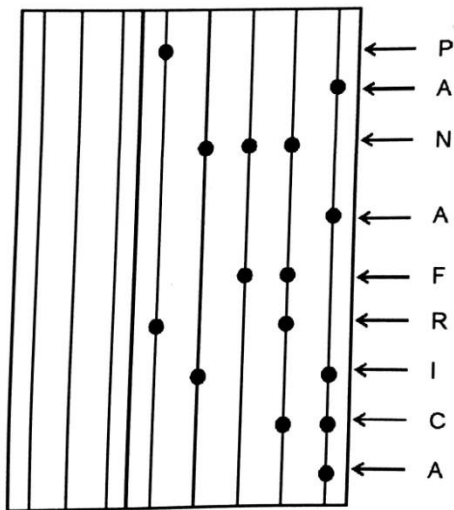

2. Decode the message on the punch card below

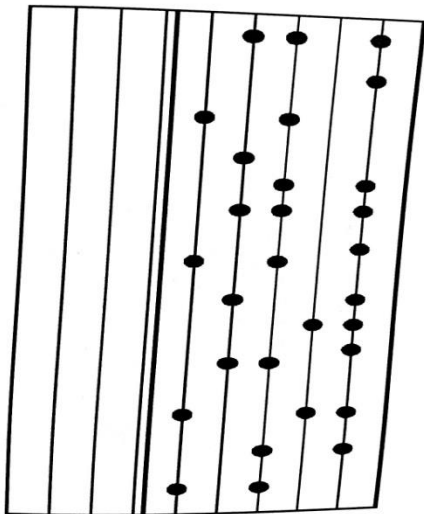

Solution

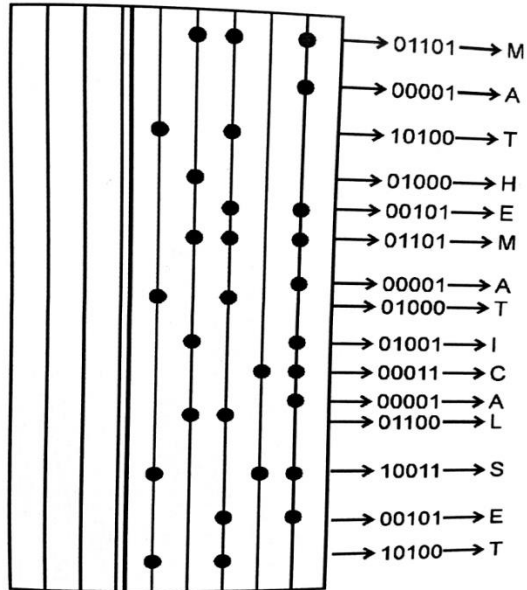

Class Activity:

1. Code the word EXCELLENCE on a punched tape.
2. Taking each letter for a line, decode the words represented by this binary code.
00110 00001 10110 01111 10101 10010

Assignment:

1. Write the binary codes for this sentence
THE DIFFERENCE BETWEEN EXTRAORDINARY AND ORDINARY IS
2. Decode the word on the following punched tape.

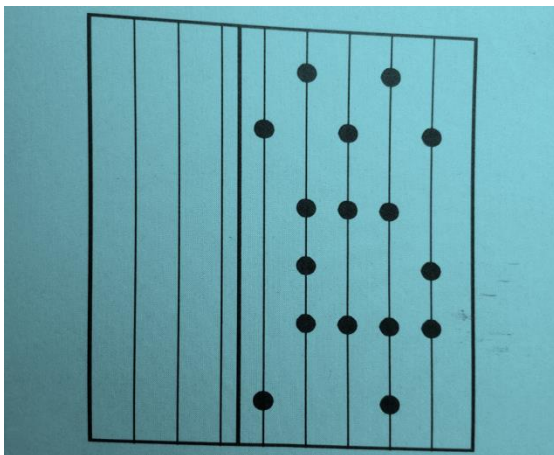

3. Code the word J S S TWO on a punched tape.
4. Taking each letter for a line, decode the words represented by this binary code.
00111 10010 00001 00011 00101

Practical Questions

1. Write the binary codes for this sentence
 - (i) I MUST BE BETTER THAN WHO I WAS YESTERDAY
 - (ii) DEEPER LIFE HIGH SCHOOL
2. Decode the word on the following punched tape.

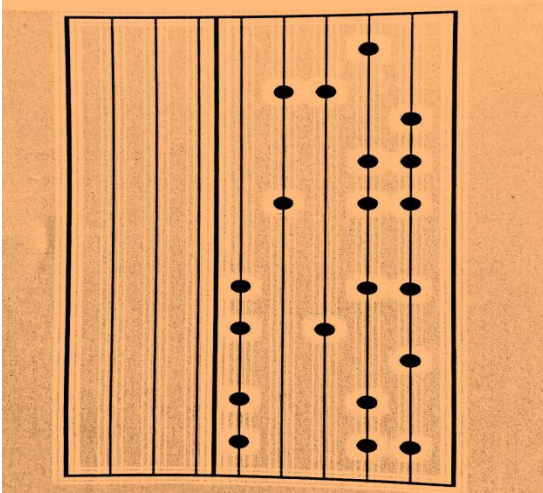

3. Code these words on a punched tape.
 - (i) INTERNATIONAL
 - (ii) TRANSPORTATION
 - (iii) THEATRE
 - (iv) OYO STATE
 - (v) SALVATION
4. Taking each letter for a line, decode the words represented by this binary code.
01101 00101 10010 00011 11001
5. The two computer input media for storing information in the past are?

TOPIC: Construction

Content

- (a) Construction of special angles (Revision)
- (b) Constructing triangles
- (i) Two sides and an included angle (ii) Two angles and a side between them. (iii) all the 3 sides
- (c) Bisecting angles: bisecting angle 90, 60 and bisect any given angles.

Construction of Special Angles

A compass, a pencil, a protractor and a ruler are the needed mathematical instruments for this construction. Angles 30° , 45° , 60° , 90° and their multiples should be thoroughly revised as a prerequisite for the next stage.

Construction of Triangles

Two sides and an Included Angle: an included angle is an angle holding two sides of the triangle.

Example 1

A protractor, a pencil and a ruler are the needed mathematical instruments for this construction.

Construct a triangle ABC, such that $AB = 4\text{cm}$, $BC = 6\text{cm}$, $\hat{B} = 62^\circ$. Measure AC.

Solution Steps

1. Make a rough sketch of the triangle

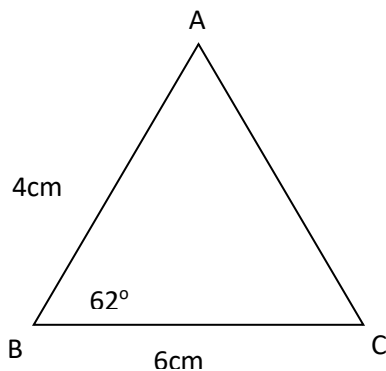

2. Draw the line $BC = 6\text{cm}$
3. Place the centre of the protractor at B. Read the inner scale on the right mark and draw angle 62°
4. Use your ruler to draw a line BX through angle B.
5. On BX, measure $BA = 4\text{cm}$ and join AC
6. Measure $AC = 5.4\text{cm}$

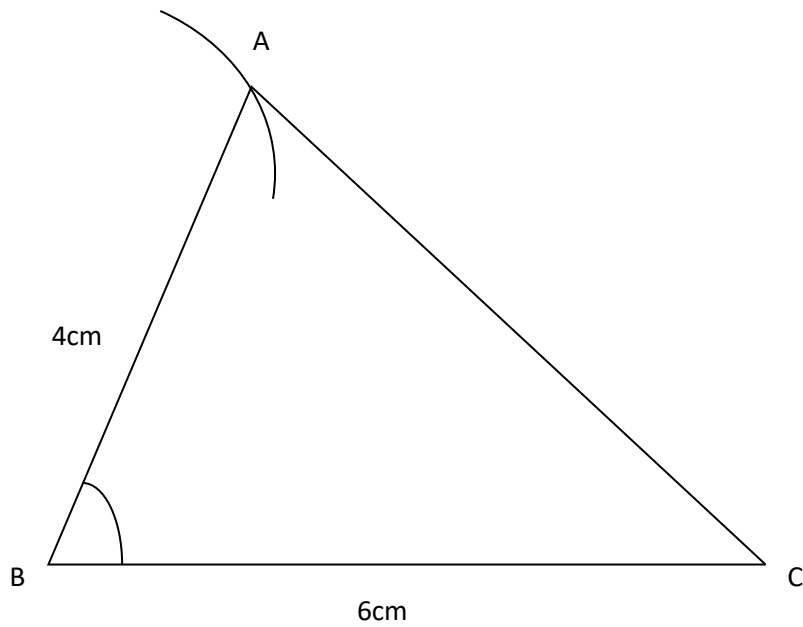

Class Activity

- 1) Construct a triangle ABC, such that $AB = 7\text{cm}$, $BC = 9\text{cm}$, $\hat{A}BC = 55^\circ$. Measure AC.
- 2) Construct a triangle DEF, such that $DE = 10\text{cm}$, $EF = 4\text{cm}$, $DEF = 38^\circ$. Measure AC.

Two Angles and a Side between them

Example 1

A protractor, a pencil and a ruler are the needed mathematical instruments for this construction.

Construct a triangle ABC, such that $BC = 5.8$, $\hat{B} = 64^\circ$ and $\hat{C} = 48^\circ$

Solution Steps

1. Make a rough sketch of the triangle

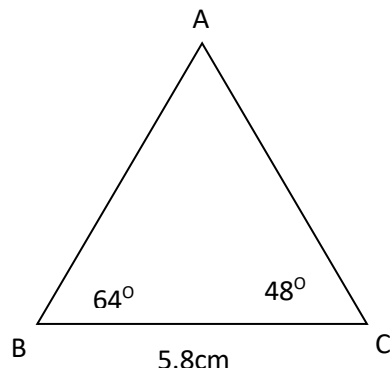

2. Draw the line $BC = 5.8\text{cm}$

- Place the centre of the protractor at B. Read the inner scale on the right mark and draw angle 64°
- Place the centre of the protractor at C. Read the outer scale on the left. Mark and draw angle 48°
- The point where the two lines intersect, mark as point A.

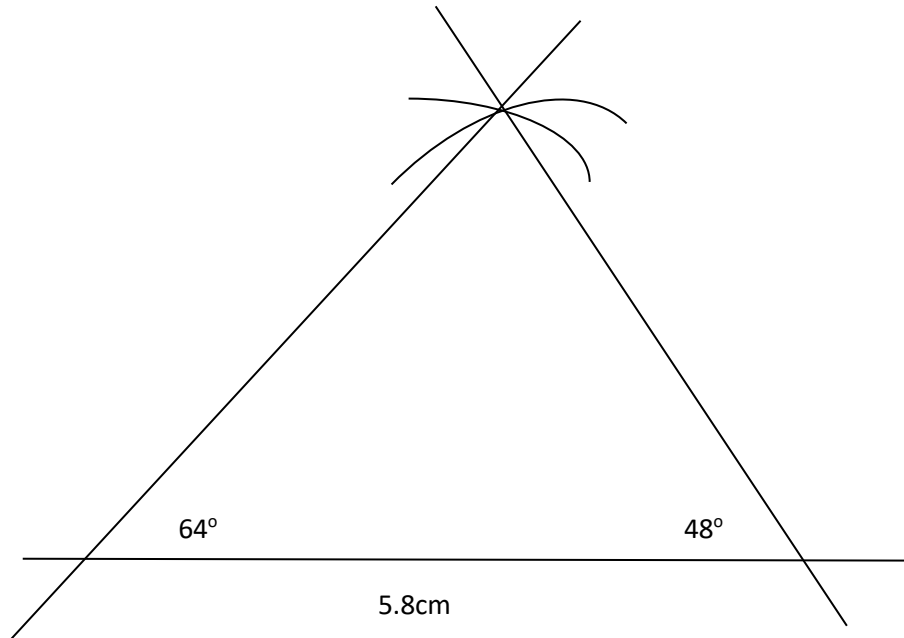

Class Activity

- Construct a triangle PQR, such that $QR = 6.8\text{cm}$, $\angle PQR = 28^\circ$, $\angle PRQ = 112^\circ$. Measure PQ.
- Construct a triangle XYZ, such that $YZ = 8\text{cm}$, $\angle Y = 50^\circ$, $\angle Z = 80^\circ$. Measure XY.

Three Sides

Example 2

Construct a triangle ABC, such that $AB = 3.8\text{cm}$, $BC = 5\text{cm}$ and $AC = 6.3\text{cm}$

Solution Steps

- Make a rough sketch of the triangle, thus

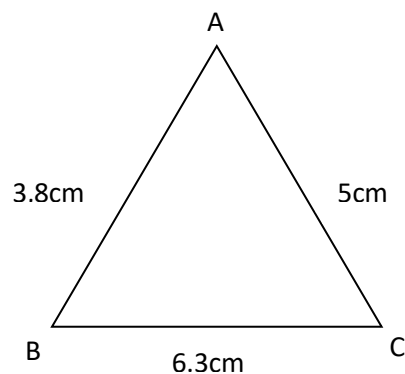

2. Draw a line segment $AC = 6.3$
3. With C as the centre and radius 5cm , draw an arc.
4. With A as the centre and radius 3.8cm .
5. Draw an arc to intersect the first arc at B.
6. Join B to A and B to C.

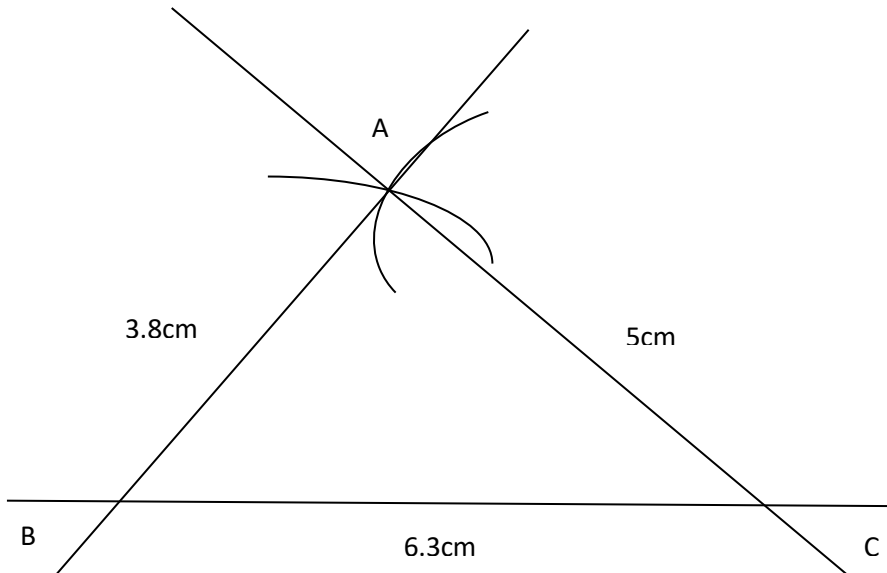

Class Activity

Construct accurately the sketches of the triangles below

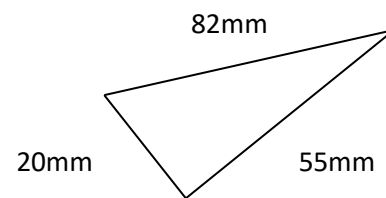
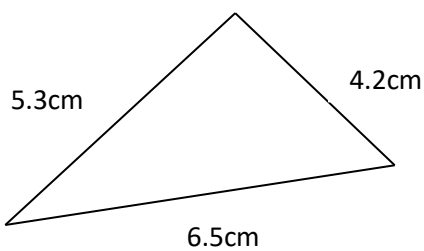

BISECTING ANGLES

To bisect an angle means to divide it into two equal angles. For example if you bisect angle 90° , you have constructed angle 45° , if you bisect angle 60° you have constructed angle 30° , etc. To

bisect an angle, you will have to construct the angle using a pair of compasses and a ruler or draw the given angle using a protractor and a ruler.

Example

1. The example shows how to use a ruler and compass to bisect the angle. Draw an angle of any size.

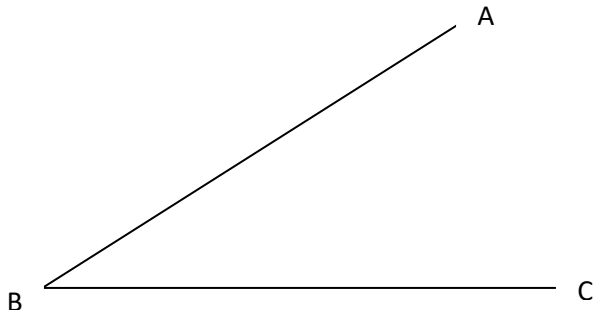

With centre B and any radius draw an arc to cut the lines BA and BC at P and Q.

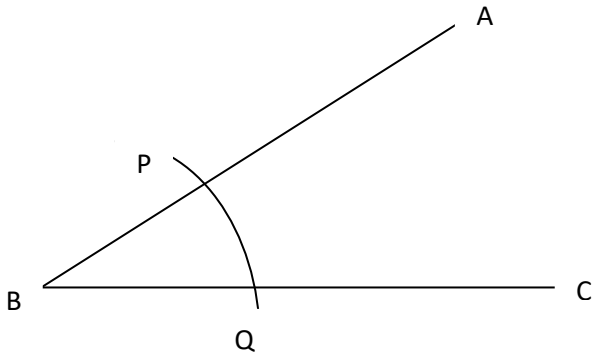

With centre P, Q and equal radii, draw arcs to cut each other at R. Join BR

BR bisect \widehat{ABC} . BR is the bisector of \widehat{ABC} . Use a protractor to check that $\widehat{ABR} = \widehat{CBR}$.

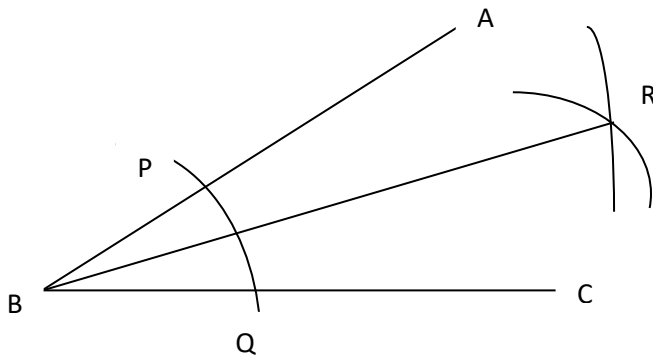

Class Activity

1. Construct then bisect angle 120° . Bisect angle 60°
2. Draw any angle ABC. Use the above method to construct the bisector of ABC. Use a protractor to check your result.

Assignment

1. Construct triangle PQR, using the dimension given;

- (a) $PQ = 6\text{cm}$ $QR = 10.5\text{cm}$ $\angle PQR = 45^\circ$
- (b) $\angle PRQ = 105^\circ$ $QR = 75\text{mm}$ $PR = 135\text{mm}$
- (c) $PQ = 6.2\text{cm}$ $\angle QPR = 60^\circ$ $PR = 90\text{mm}$

2. (a) Draw a scalene triangle PQR such that \hat{Q} is obtuse.

- (b) Construct the bisector of \hat{P} , \hat{Q} and \hat{R}
- (c) If necessary extend each bisector so that it cuts the other two.
- (d) What do you notice about the three bisectors?

Practice Questions

1. Draw the triangles with these given dimensions .find the third side and the other angles.

- (a) $\triangle ABC$; given that $AB = 8.2\text{cm}$, $AC = 5.6\text{cm}$ and $\hat{BAC} = 103^\circ$
- (b) $\triangle XYZ$; given that $XZ = 25\text{mm}$, $\hat{YXZ} = 40^\circ$ and $\hat{XZY} = 87^\circ$
- (c) $\triangle DEF$; given that $DE = 4.8\text{cm}$, $DF = 6\text{cm}$ and $EF = 13\text{cm}$

2. Draw any angle ABC. Use the above method to construct the bisector of \hat{A} . Use a protractor to check your result.

3. (i) Construct an isosceles triangle XYZ such that $XY = YZ = 8\text{cm}$ and $\angle XYZ = 60^\circ$

- (ii) Construct the bisector of angle Y
- (iii) Construct the perpendicular bisector of side XY

4. (i) Draw a triangle with sides 6cm, 8cm and 10cm.

- (ii) Bisect the smallest angle

(iii) The bisector cuts opposite side into two parts. Measure the lengths of the two parts.

WEEK 8

TOPIC: DATA PRESENTATION

CONTENT:

- **Data and Types of Data**
- **Presentation of data**
 - (i) Frequency tables: ungrouped and grouped.**
 - (ii) Pie Chart: construction and interpretation.**

Data and Types of Data

The word data means information, which is usually given in the form of numbers or facts. Data may be categorized into two major groups, namely;

a) Qualitative / Categorical data. They are non numerical and are described only in words. Examples are names, places, color, taste, opinions, and brightness.

b) Quantitative data: They are numerical data which are usually given in form of a number or measurement. Examples are number of cars, height of people, number of schools, number of admissions, etc. Quantitative data can be further classified into:

i) Discrete data: They are obtained usually by counting and not by measurements. Most often they are whole numbers and not fractions / decimal numbers. The sense is that we can only say we have 6 houses and not $6\frac{1}{2}$ houses; we have 4 boys and not $4\frac{3}{4}$ boys. Thus, discrete data have certain definite or exact values.

ii) Continuous data: They are data which are obtained by measurements. They can take any values within a given range, including fractions and decimals. Continuous data concerns more with precision of figures or numbers' measurements, perhaps using instrument. Examples of continuous data are heights, distances, temperature, areas, perimeters, volumes, density, mass, angles, etc. This is so because these may not be whole numbers in most practical situations.

Class Activity

- 1) What is Data?
- 2) Mention the various categories of Data.

Presentation of Data

Ordered Presentation of data is the arrangement of data in a way that will make them look organized and more presentable. Ordered presentation of data also makes statistical data easy to read, understand and interpret. Data containing numbers can be presented in an ordered format through:

- Sorting

- Use of frequency table
- Graphs.

SORTING

This involves arranging data either from the least to the highest (increasing or rank order) and vice versa. When data are not sorted out and not arranged to taste, we say they are still in the raw state and are therefore called as raw data. Data sorted out in increasing order are said to be given in **Rank Order**. In a Rank Order, the Range of the set of data can be calculated.

Range: The range of any set of data is the difference between the largest value and smallest value. For instance, given the set of numbers:

5, 8, 3, 2, 17, 9, 13, 6, 4

$$\text{Range} = 17 - 2 = 15$$

Range can also be written as $2 \rightarrow 17$, meaning that the data ranges from 2 to 17.

Example:

Question: The raw scores of 20 pupils in a Mathematics test are:

6, 8, 10, 5, 2, 10, 6, 9, 4, 3, 10, 5, 6, 9, 8, 7, 7, 6, 6, 3

- Arrange the scores in the order of magnitude starting with the smallest.
- Arrange the scores in the order of magnitude starting with the largest.
- What is the difference between the least and the highest scores?
- How many pupils scored less than 6?
- How many pupils have the lowest score; and how many have the highest score?
- If the pass mark is 7 how many failed and how many passed?

Solution:

(a) 2, 3, 3, 4, 5, 5, 6, 6, 6, 6, 6, 7, 7, 8, 8, 9, 9, 10, 10, 10

(b) 10, 10, 10, 9, 9, 8, 8, 7, 7, 6, 6, 6, 6, 6, 5, 5, 4, 3, 2, 2

(c) Range = Highest score – Lowest Score
 $= 10 - 2$
 $= 8$

(d) Less than 6 = Numbers from 2 to 5

2, 3, 3, 4, 5, 5

Therefore 6 pupils scored less than 6 marks

(e) Lowest score = 2, Therefore 1 pupil has the lowest score

Highest score = 10, Therefore 3 pupils have the highest score

(f) Pass mark = 7 or more,

Pass scores = 7, 7, 8, 8, 9, 9, 10, 10, 10. Therefore 9 pupils passed

Fail mark = Less than 7

Fail scores = 2, 3, 3, 4, 5, 5, 6, 6, 6, 6, 6. Therefore 11 pupils failed

Class Activity

The raw scores of 20 pupils in a Basic Science test are:

16, 8, 10, 5, 4, 20, 16, 9, 14, 13, 10, 5, 6, 19, 28, 12, 17, 22, 11, 13

- Arrange the scores in the order of magnitude starting with the smallest.
- Arrange the scores in the order of magnitude starting with the largest.
- What is the difference between the least and the highest scores?
- How many pupils scored less than 20?
- How many pupils have the lowest score; and how many have the highest score?
- If the pass mark is 15 how many failed and how many passed?

FREQUENCY AND FREQUENCY TABLES

Ungrouped data

The frequency of a particular data value is the number of times the data value occurs. For example, if four students have a score of 80 in mathematics, and then the score of 80 is said to have a frequency of 4. The frequency of a data value is often represented by f .

A frequency table is constructed by arranging collected data values in ascending order of magnitude with their corresponding frequencies. This table shows the arrangement of data in at least two columns, where the first column indicates the **items** from the least to the highest and the second column indicates the **frequencies**. There can also be the third column for **tally**.

EXAMPLE

In general, we use the following steps to construct a frequency table:

Step 1:

Construct a table with three columns. Then in the first column, write down all of the data values in ascending order of magnitude.

Step 2:

To complete the second column, go through the list of data values and place one tally mark at the appropriate place in the second column for every data value. When the fifth tally is reached for a mark, draw a horizontal line through the first four tally marks as shown for 7 in the above frequency table. We continue this process until all data values in the list are tallied.

Step 3:

Count the number of tally marks for each data value and write it in the third column. For example, the 20 raw scores of students given below can be re-organized in a frequency- table:

2, 3, 3, 4, 5, 5, 6, 6, 6, 6, 6, 7, 7, 8, 8, 9, 9, 10, 10, 10

Item/Score(x)	Tally	Frequency(f)
2		1
3		2
4		1
5		2

6		5
7		2
8		2
9		2
10		3
TOTAL		20

The above explanation describes a frequency table for data values that are not too many and can each be represented on the frequency table.

Grouped data: Class Intervals

The frequency of a class interval (or group) is the number of data values that fall in the range specified by that group (or class interval). When the set of data values are spread out, it is difficult to set up a frequency table for every data value as there will be too many rows in the table. So the data are grouped into class intervals (or groups) to help us organize, interpret and analyze the data.

Ideally, there should be between five and ten rows in a frequency table. Bear this in mind when deciding the size of the class interval (or group).

Each group starts at a data value that is a multiple of that group. For example, if the size of the group is 5, then the groups should start at 5, 10, 15, 20 etc. Likewise, if the size of the group is 10, then the groups should start at 10, 20, 30, 40 etc.

EXAMPLE

The number of calls from motorists per day was recorded for the month of December 2003. The results were as follows:

28 122 217 130 120 86 80 90 120 140
70 40 145 187 113 90 68 174 194 170
100 75 104 97 75 123 100 82 109 120
81

Set up a frequency table for this set of data values using class interval of 40.

Solution:

Construct a table with three columns, and then write the data groups or class intervals in the first column. The size of each group is 40. So, the groups will start at 0, 40, 80, 120, 160 and 200 to include all of the data.

Class interval	Tally	Frequency
0 - 39		1
40 - 79		5
80 - 119		12
120 - 159		8
160 - 199		4
200 - 239		1
	Sum =	31

Class Activity

- The marks awarded for an assignment set for a Year 8 class of 20 students were as follows: 6 7 5 7 7 8 7 6 9 7 10 6 8 8 9 5 6 4 8

Present this information in a frequency table.

- The masses, in kg of 40 people are as follows:

59	51	59	60	59
62	63	58	56	62
61	58	54	62	69
56	60	62	51	70
54	56	61	61	58
61	64	57	60	60
65	57	52	67	49
58	60	58	57	63

Set up a frequency table for this set of data values using class interval of 5.

PIE CHART: CONSTRUCTION AND INTERPRETATION.

Meaning of Pie Chart:

A pie chart is made up of a circle used to represent the frequency of each item in form of angle. To draw the pie chart, convert the frequencies to angles. A pie chart is a circular chart in which the circle is divided into sectors. Each sector visually represents an item in a data set to match the amount of the item as a fraction of the total data set. In a pie chart, the arc length of each sector is proportional to the frequency it represents. It is named for its resemblance to a pie which has been sliced.

The pie chart is perhaps the most widely used statistical chart in the business world and the mass media. A Pie chart is useful to compare different parts of a whole amount. It is often used to present financial information. E.g. A Company's expenditure can be shown to be the sum of its parts including different expense categories such as salaries, borrowing interest, taxation and general running costs (i.e. rent, electricity, heating etc).

Drawing a Pie Chart

A pie chart is drawn with the help of a table which transforms the data into fractions of the total and angles. The angles are obtained by multiplying each fraction by 360° .

The table normally contains 4 columns.

In the first column, the event for each category of data is indicated. In the second column, the frequency or value of each event is indicated. In the third column, the frequencies are converted to fractions of the total frequency. In the fourth column, the fractions are converted to angles.

Check your calculations by totaling the angles listed in the fourth column. The sum of angles should be equals to 360° .

Then draw a circle and divide the circle into sectors, each sector representing each of the angles obtained.

Title your chart and indicate the legend (or keys) of your chart.

Example

1. A family's weekly expenditure on its house mortgage, food and fuel is as follows:

Expense	\$
Mortgage	300
Food	225
Fuel	75

Solution

Expenses	Cost (\$)	Sector size	Percentage
Mortgage	300	$\frac{300}{600} \times 360^\circ = 180^\circ$	$\frac{300}{600} \times 100\% = 50\%$
Food	225	$\frac{225}{600} \times 360^\circ = 135^\circ$	$\frac{225}{600} \times 100\% = 37.5\%$
Fuel	75	$\frac{75}{600} \times 360^\circ = 45^\circ$	$\frac{75}{600} \times 100\% = 12.5\%$

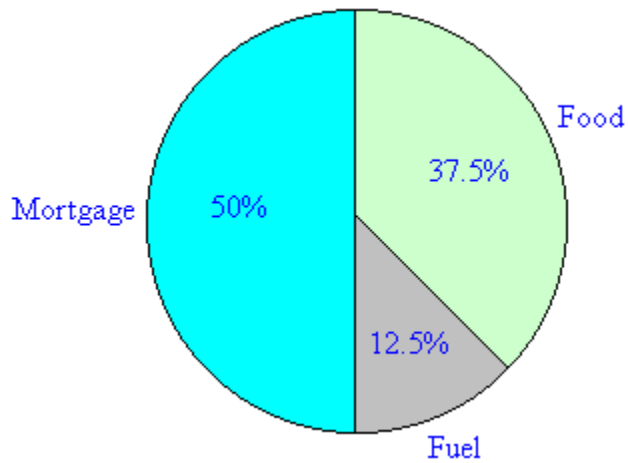

Note: It is simple to read a pie chart. Just look at the required sector representing an item (or category) and read off the value. For example, the weekly expenditure of the family on food is 37.5% of the total expenditure measured. A pie chart is used to compare the different parts that make up a whole amount.

2. The following table represents the grades obtained by 15 students in an examination.

Grade	A	B	C	D	E	F
Frequency	3	5	3	1	2	1

Solution

Converting the frequencies of the items to angles:

Grade	frequency	Sector Angle
A	3	$\frac{3}{15} \times 360^\circ = 72^\circ$
B	5	$\frac{5}{15} \times 360^\circ = 120^\circ$
C	3	$\frac{3}{15} \times 360^\circ = 72^\circ$
D	1	$\frac{1}{15} \times 360 = 24^\circ$

E	2	$2/15 \times 360^\circ = 48^\circ$
3F	1	$1/15 \times 360^\circ = 24^\circ$
TOTAL	15	360°

Angle of each frequency = $\frac{\text{Frequency}}{\text{Total frequency}} \times 360^\circ$

The angles for the items (grades) are then represented in a circle as follows:

Note: The key is the list of the colour used to represent each item.

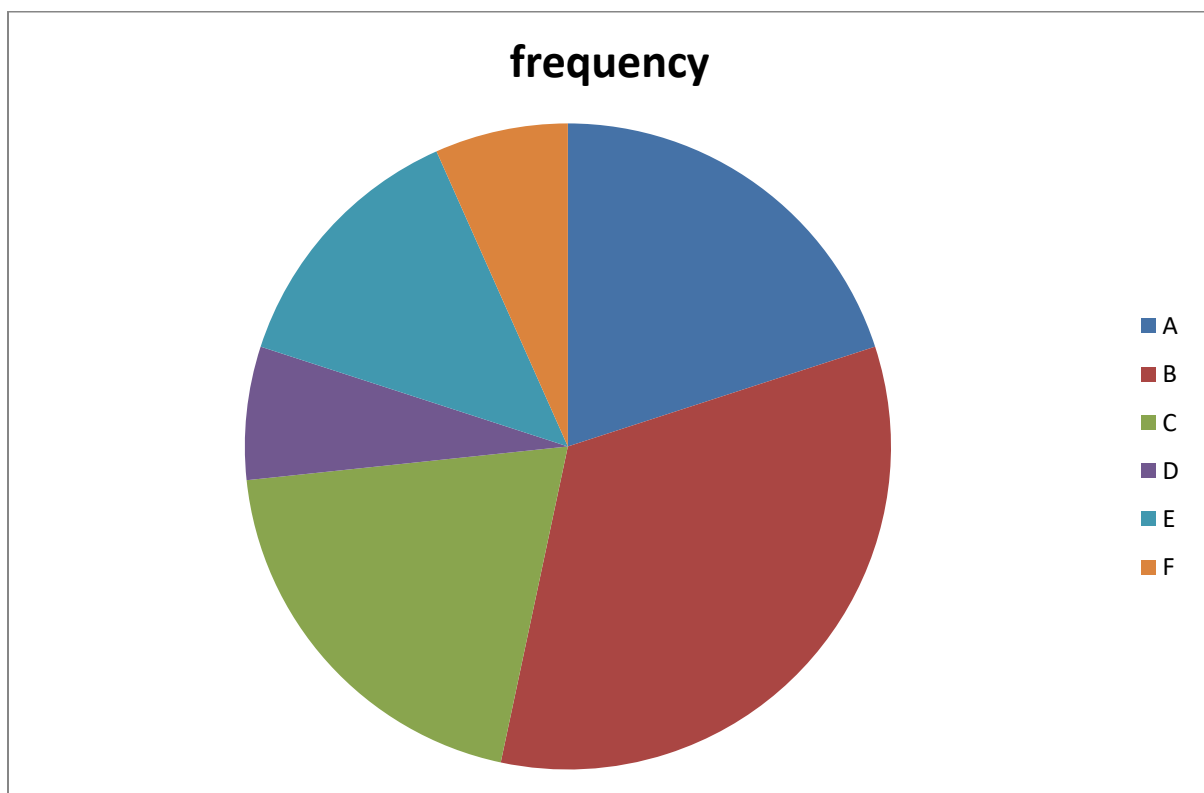

Class Activities

- The data below, shows the number of mechanical faults of a machine within the first six months of a particular year. Draw the pie-chart diagram to represent the information.

Month	January	February	March	April	May	June
Frequency	2	4	6	10	6	2

2. The following chart is based on results of the election for the European Parliament in 2004. The table lists the number of seats allocated to each party, along with the derived fraction of the total that they each make up. The value in the last column, the derived angle of each sector, is found by multiplying the derived fraction by 360° .

Group	A	B	C	D	E	F	G	H
Seats	39	200	42	15	67	276	27	66

Class Activities

Represent the data below with a pie-chart

Grade	A	B	C	D	E	F
frequency	3	5	3	1	2	1

Assignment:

1. The data below represent the daily units of electricity used by a certain household in September. 25, 14, 17, 12, 8, 17, 13, 17, 4, 25, 2, 8, 15, 4, 7, 14, 18, 7, 6, 5, 28, 32, 30, 19, 11, 14, 22, 4, 11, 9.

- (a) Represent the information by a frequency table.
 (b) Draw a pie chart to represent the information on the table.

2. The examination marks of 50 students are as follows:

65	50	48	38	58
46	47	37	45	48
71	43	80	59	51
60	42	40	62	60
44	36	39	51	67
58	67	40	50	40
59	32	26	39	55
51	52	74	70	
69	47	53	58	
54	23	61	73	
51	46	40	59	

Set up a frequency table for this set of data values using class interval of 10.

3. Harry asked each student in his class how they travelled to school that day. He used the results to draw this pie chart. Use the pie chart to answer the questions below

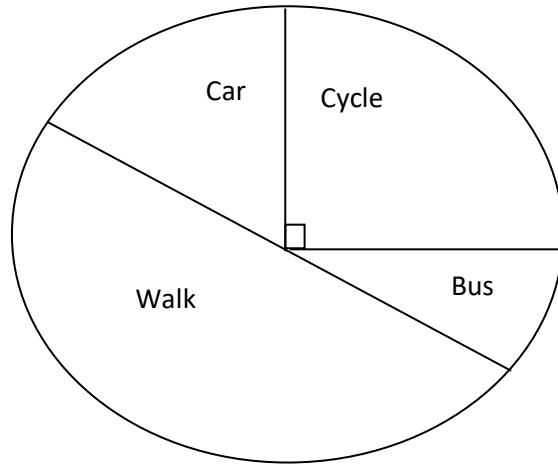

- (a) How did most of the students travel to school?
- (b) If Harry asked a total of 24 students. The number of students who cycled to school is?
- (c) What percentage of the students came to school by car and bus?

Practical Questions

1. The shoe sizes for 25 adults are recorded as follows:

7	9	8	9	8
10	9	10	11	9
7	6	10	6	9
10	8	10	9	11
9	8	8	11	9

- (i) Prepare a frequency table for the data.
- (ii) Represent the data in a pie chart

2. The data below shows the grade of 60 students in the Senior School Certificate examination in Mathematics

E8	A1	E8	C4	C4	B2
A1	B2	B3	E8	B2	E8
B2	B2	E8	F9	A1	E8
B2	E8	F9	B2	B2	C4
C4	B3	E8	C4	B3	B3
E8	E8	B2	A1	B3	B3
E8	F9	A1	C4	B3	A1
B3	A1	B3	D7	A1	B2
F9	B2	A1	D7	F9	C4
B3	C4	C4	A1	C4	B3

- (i) Construct a frequency table for this data.

- (ii) Draw a bar chart to represent the data.
- (iii) Draw a pie chart to represent the data.
3. Shalom recorded the musical instrument played by each of 30 students in the school orchestra. The table shows her results:

Musical Instrument	Clarinet	V i o l i n	F l u t e	Saxophone
F r e q u e n c y	5	1 2	7	6

- (ii) Draw an accurate pie chart to show the information shown in the table.

WEEK 9

TOPIC: PROBABILITY

CONTENT:

- Definition of terms in probability
- Experimental probability
- Theoretical probability

Definition of Terms in Probability

Probability is a measure of the likelihood of an event happening, that is, the likelihood of a required outcome. The required outcomes are the required possibilities in an occurrence or happening.

In form of a fraction, Probability = $\frac{\text{number of required outcomes}}{\text{number of possible/total outcomes}}$

The result (value) of this fraction ranges between 0 and 1.

Probability is 1 if it is certain that something will happen. Probability is 0 if it is certain that something cannot happen.

Probability is ordinarily used to describe an attitude of mind towards some proposition of whose truth we are not certain. The proposition of interest is usually of the form "Will a specific event occur?" The attitude of mind is of the form "How certain are we that the event will occur?" The **certainty** we adopt can be described in terms of a numerical measure and this number, between 0 and 1, is called probability. The higher the probability of an event, the more certain we are that the event will occur. Thus, probability in an applied sense is a measure of the likeliness that a (random) event will occur.

If the probability of something happening is x

Then the probability of it not happening is $1 - x$.

Application Areas of Probability

There are lots of these simple examples that we could be used to discuss probability. But chance events occur more often in everyday life. As you grow up you need to think about your

actions and what the consequences of these actions will be. It's important to know how to use probability when you make decisions about your future.

There are many advertisements on TV for trading stocks which involve buying and selling shares from companies. Before buying a stock, there is need to investigate the company. If the company makes a lot of money with their product and if you own some of their stock, you may make more money, potentially more money than what you could earn at the bank as interest on your savings account. But if the company loses money, you may lose. People who work with company finances calculate the probability that a company should make money and is a good company to invest money in.

Another area of your life where probability is important is your health. For example, if you know that people in your family have heart disease and you develop high blood pressure when you are an adult then you know that you have a high probability of also having heart disease. You could be frightened by this high probability or you could live a healthier lifestyle that lowers your blood pressure and in turn lowers the probability of getting heart disease. In this case, you are using your understanding of probability to improve your health.

Experimental Probability

Chance is a word that is used in everyday life situation, mostly in games of luck where chances of a particular event taking place are discussed.

A person can have a chance of meeting a person or winning a game. A weak student has a chance to get good marks, if he studies. In very simple terms, chance is something that may happen, even if there were no scene of its happening. It can be seen that chance is a term that describes the likelihood of an event taking place.

There is a difference between Chance and Probability:

Probability is a separate field of study originated from the study of games of chances. Tossing a coin, spinning a wheel and rolling a dice in Ludo game are perfect examples. Chance is an everyday word used in a situation where we are talking about an event taking place whereas probability is a precise measurement of that chance. Probability is a special branch of mathematics that helps people to decide the percentage of likelihood of an event taking place whereas chances of an event taking place in daily life are merely opinions.

For example, in a game of Ludo, the probability of getting a six is $\frac{1}{6}$. There are six numbers around a die: 1, 2, 3, 4, 5, 6. The probability of getting a 6 out of the six digits round a die is 1 out of 6.

When a coin is tossed, there are two possible outcomes. It can be a head or a tail, which are both equally likely. If two coins are tossed, there can be two heads, two tails, or a head and a tail. It is tempting to say that there are three equally possible outcomes. But this would be wrong. You must think of the coins separately. It might be easier to imagine tossing one coin first and the other after (or even tossing the same coin twice, which has exactly the same effect). Or you could imagine two different values of coins, so they can be tossed apart. Now you can see that there are four possibilities: both heads, both tails, first coin a head and the second a tail, and first coin a tail and the second a head.

Example 1:

1. A coin is tossed three times. The probability of obtaining at least one tail is?

Solution:

Probability of getting a head: 0.5

Probability of getting a tail: 0.5

The probability of not getting ANY tails = P (Head) x P (Head) x P (Head)

$$= 0.5 \times 0.5 \times 0.5$$

$$= 0.125$$

The probability of getting AT LEAST 1 tail = $1 - 0.125 = 0.875$

Other examples of the probabilities of chance events include: probability of getting rain is $\frac{1}{2}$ (or 50%), probability of passing a competitive exam is $\frac{1}{2}$ (or 50%), and probability of winning a football match is $\frac{1}{2}$ (or 50%).

Example 2:

Find the probability of obtaining a 4 on a thrown die.

Solution :

Likely numbers to throw are :1,2,3,4,5,6

Event number is 4, i.e number of required outcomes which occur once

While total number is 6 i.e required outcomes

Probability of obtaining a 4 i.e $P(4) = 1/6$

Example 3:

It is known that out of every 1000 new cars, 50 develop a mechanical fault in the first three months. What is the of buying a car that will develop a mechanical fault within 3 months.

Solution :

Required outcomes is number of cars developing faults = 50

Total number of outcomes is number of cars altogether = 1000

Probability of buying a faulty car = $\frac{50}{1000} = \frac{1}{20}$

Class Activity:

- 1) A coin is tossed twice. What is the probability of getting a head and a tail?
- 2) What is the probability of getting a 5 from a Ludo die?
- 3) Briefly discuss the importance of probability.

THEORETICAL PROBABILITY

EXAMPLE – 1: Out of 200 buses, 40 were not involved in any accident in January. What is the probability that a bus will not be involved in accident in January?

Solution:

Required outcomes = Numbers of buses not involved in accident in January = 40

Possible outcomes = Number of buses altogether = 200

Probability of a bus not involved in accident in January = $\frac{40}{200} = \frac{1}{5}$

EXAMPLE – 2: In a basket, there are two blue balls, three red balls and four green balls. What is the probability that a ball picked at random is:

- (i) Blue
- (ii) Red
- (iii) Green
- (iv) Not Blue

Solution:

Random means not picked carefully or selected anyhow.

$$(i) \quad \text{Probability of picking Blue ball} = \frac{\text{Number of Blue balls}}{\text{Total Number of balls}}$$

$$= \frac{2}{9}$$

$$(ii) \quad \text{Probability of picking Red ball} = \frac{\text{Number of Red balls}}{\text{Total Number of balls}}$$

$$= \frac{3}{9}$$

$$(iii) \quad \text{Probability of picking Green ball} = \frac{\text{Number of Green balls}}{\text{Total Number of balls}}$$

$$= \frac{5}{9}$$

$$(iv) \quad \text{Probability of not picking Blue ball} = 1 - \text{Probability of picking Blue ball}$$

$$= 1 - \frac{5}{9}$$

$$= \frac{9-5}{9}$$

$$= \frac{4}{9}$$

EXAMPLE – 3: A bucket contains 7 big mangoes and 21 small mangoes. What is the probability that a mango selected at random is:

- a) Big
- b) Small
- c) Either
- d) Neither

Solution:

a) Probability of selecting big mango = $\frac{\text{Number of Big mangoes}}{\text{Total Number of mangoes}}$

$$= \frac{7}{7+21}$$

$$= \frac{7}{28}$$

Reducing the fraction to its lowest term,

$$= \frac{1}{4}$$

b) Probability of selecting small mango = $\frac{\text{Number of Small mangoes}}{\text{Total Number of mangoes}}$

$$= \frac{21}{7+21}$$

$$= \frac{21}{28}$$

Reducing the fraction to its lowest term,

$$= \frac{3}{4}$$

c) Probability of selecting either big or small mango =

Probability of selecting big mango + Probability of selecting small mango

$$= \frac{1}{4} + \frac{3}{4}$$

$$= \frac{4}{4}$$

$$= 1$$

Reducing the fraction to its lowest term,

$$= \frac{1}{4}$$

d) The mangoes are either big or small. It is therefore impossible to select any other size apart from big or small.

Probability of neither big nor small = $\frac{0}{7+21} = \frac{0}{28}$

$$= 0$$

Class Activity

1. A bag contains 5 white balls and 6 yellow balls. What is the probability that a ball picked from the bag at random is:

- (a) White (b) Yellow (c) Either White or Yellow (d) Neither White nor Yellow

2. There are 7 red balls, 8 white balls and 5 blue balls in a box. A ball is selected at random from the box. Find the probability that the ball is:

- (a) White (c) Blue Or Red (e) Green.
(b) Red (d) Neither Red nor White

Assignment

1. A trader has 100 mangoes for sale. Twenty of them are unripe. Another five of them are bad. If a mango is picked at random, find the probability that it is:

- (a) Unripe (b) Bad (c) Neither unripe nor bad?

If 20 of the mangoes were chosen at random, how many would you expect to be:

- (d) Unripe (e) Bad

2. A bag contains 4 white, 3 black, 2 blue and 1 red marbles. A man is asked to pick a marble randomly from the bag. Find the probability that the marble picked is:

- (a) White (c) Blue (e) White or black
(b) Black (d) Red (f) Blue or red

3. The probability of getting an even number from the throw of a fair die is

4. A bag contains 5 white balls and 6 yellow balls. What is the probability that a ball picked from the bag at random is:

- (a) Either White or Yellow.
(b) Neither White nor Yellow

5. A coin is tossed twice. What is the probability of getting a head and a tail?

Practice Questions

1. A bag contains 5 white, 3 black and 2 blue balls. If one ball is picked at random from the bag. Calculate the probability that it is:

- (a) White (c) Blue (f) Blue or black
(b) Black (e) White or blue

2. Two fair coins are tossed together find the probability that:

- (a) Two heads appear (b) Two tails appear (c) A head and a tail appear

3. If I have cards numbered 1,3,5,7,9,find the probability of
- (a) Picking an even number (c) Picking 9
 (b) Picking a number less than 6 (d) Picking a odd number
4. Shalom recorded the musical instrument played by each of 30 students in the school orchestra. The table shows her results:

Musical Instrument	Clarinet	V i o l i n	F l u t e	Saxophone
F r e q u e n c y	5	1 2	7	6

One of the students in the school orchestra is chosen at random. Find the probability that the student plays

- (a) Flute. (d) Violin and flute
 (b) Clarinet (e) None of the musical instruments.
 (c) Saxophone or clarinet
4. Sam, Kara and lee entered a race with 9 other people. Assuming that all runners have equal chance of winning
- (i) What is the probability that Sam will be first, Kara will be second and lee will be third?
 (ii) What is the probability that Sam, Kara and Lee will finish in the top 3?
 (iii)What is the probability that NONE of them will finish in the top 3?