

JSS 2 BASIC 8)
BASIC TECHNOLOGY

WEEK TOPIC

1. Revision of second term's work

SUB- THEME: TOOLS, MACHINES AND PROCESS.

2. Belt and chain Drives: (a) Examples of belt drives (b) Application of belt and chain drives (c) Advantages and disadvantages of belt and chain drives.
3. Air flow, Hydraulic and Pneumatic Machines: (a) Definition and types of air flow (b) Examples of Hydraulic and Pneumatic Drives (c) Components of the machines (d) Operation and uses of hydraulic and pneumatic (e) Advantages of pneumatics and hydraulic devices.
4. Gear: (a) Types of gear; internal gear, external gear and level gear (b) Uses of gears; for power transmission, changing of direction, selecting speed, etc. (c) Gear ratio and speed rotation (d) Function of lubricants in gears.

SUB- THEME: PROCESSING OF MATERIALS

5. **WOOD** (i) Timber growth, felling, conversion and seasoning (ii) Properties of good timber preservatives (iii) Common timber defects; twist, bowing, cupping, etc. (iv) Methods of cutting veneers etc.
6. **WOOD** cont'd: (v) Types of Manufactured boards – plywood, chip board, block board, etc. (vi) Timber: Treatment and timber preservation methods (vii) Importance of timber treatment.
7. MID TERM BREAK
8. **METALS** (i) Production of metals; smelting, casting, etc. (ii) Carbon properties of steels (iii) Types metal (iv) Metal alloys. **CLAY, CERAMICS AND GLASS** (i) Methods of making clay (ii) Stages in producing Ceramics and Glass materials; shaping, blowing, firing etc.
9. **PLASTICS AND RUBBER:** (i) Methods of production of plastics; injection molding, calendaring, etc. (ii) Methods of producing rubber materials; natural and synthetic (iii) Examples of plastics and rubber products (iv) Advantages and disadvantages of the different processing methods. (v) Uses of plastic and rubber.
10. Revision.

11 – 13. Examination.

WEEK ONE: Revision of second term's work

WEEK TWO SUB- THEME: TOOLS, MACHINES AND PROCESS

TOPIC: BELT AND CHAIN DRIVES.

Period ONE: Belt and Chain drives.

Content: Definition, examples/types of belt and chain drives, belt tensioning.

- Drives
- Belt drive
- Types of belt drive
- Belt tensioning
- Application of belt drive
- Chain drive
- Application of chain drive
- Difference between chain drive and gear drive

Drives: Drives are devices used to **transmit rotary motion** from one shaft to another.

The drive mechanism is used in transmitting power from one location to another

There are **three** types of drives:

1. ***Belt and pulley drive***
2. ***Chain drives***
3. ***Gear drives***

Belt drive

This is a device used to **transfer power/motion** from one shaft to another **shaft parallel** to it and **at some distance away**. Belt drives are often used in place of chain drive when slip is not so important to be taken into consideration. Hence, **belt cannot provide positive drive** because slip occurs from time to time.

Types of belt drive

There are two types of belt drive based on the shape of the belt:

1. **Straight (flat) belt**
2. **V- shaped belt**

Belt can be lapped over the groove pulley in two styles. This includes:

- i. ***Straight belt lap:*** Here the two pulleys join by the belt rotate in the same direction.
- ii. ***Cross belt lap:*** Here the two pulleys join by the belt rotate in opposite

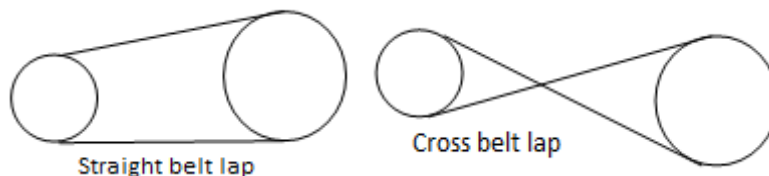

Belt tensioning

Sometimes, a belt in use is slack and may be slipping over the pulley. Such belts that are not taut do not transmit motion/power effectively thereby wasting energy. This could be prevented by **tensioning** the belt drive.

To tension a belt, another pulley (wheel called the **idler**) mounted on a separate shaft is used.

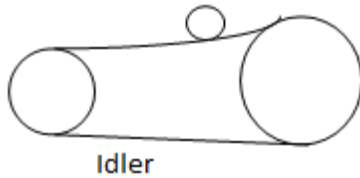

Application of belt drive

1. They are used to couple a diesel engine to an alternator to generate electricity
2. They are used in cassava grinding machines
3. They are used for the radiator of cars.
4. They are used for tape recorders/ video cassette players
5. They are used in the engines of automobiles (Volkswagens –tortoise car)
6. They are used in block making machines



Period 2: Chain drives

They are used for transferring power/motion from one shaft to another just as in the case for belt drive. Chain is always used in conjunction with a sprocket for transmitting power. A sprocket is a toothed wheel or a wheel with many contours round its circumference. The number of teeth on the sprockets determines the speed of rotation of the driven sprocket.

One advantage of the chain and sprocket drive over the belt drive is that it has a **firmer grip** on the area of lap than the belt drive. Chain drives do not allow slip unlike belt drive. Also, power is transmitted positively in chain drive and not by friction as in the case of belt drives.

In chain drive, the driver and the driven sprocket rotate in the same direction just as in the case of straight belt lap. Both the chain drive and the belt drives are used to transmit power and motion between two shafts at some distance apart.

Applications of chain drive.

1. The motorcycle chain drive
2. The bicycle chain and sprocket drive.
3. Mechanical saw for slicing wood.



© Can Stock Photo - csp1745489

Differences between chain drive and the gear drive

Chain drive	Gear drive
1. Power is transmitted between two shafts at some distance apart	Power is transmitted between very close shafts such that the teeth on the wheels mesh together.
2. Power is transmitted positively i.e power transmission do not engages friction	Friction occurs between the meshed teeth of the gears.
3. Chain drives are used to transmit motion only between two parallel shafts.	Gear drives could be used to transmit motion between parallel as well as inclined shafts.
4. The driven and the driver sprocket rotate in the same direction	The driven and the driver wheel rotate in opposite direction.

SIMILARITIES BETWEEN BELT, CHAIN AND GEAR DRIVES.

- (1) All the three drives are used for transmission of energy from one place to another.

(2) all find their application in one mechanical device or the other depending on the circumstances.

Practical

The teacher should allow the students opportunity to inspect the following

- i. Bicycle chain and sprocket drive
- ii. Interior of a radio cassette player with the belt in action or the belt of the car radiator in action
- iii. Ball bearing for reducing friction.

The students are to make note and discuss among themselves their various observations.

EVALUATION

1. A force which opposes motion is called --- (a) tension (b) elastic (c) friction (d) pull
2. A process of applying a substance to machine parts in order to reduce friction is called --- (a) lubrication (b) elimination (c) banking (d) friction control
3. --- is a type of friction which occurs between two bodies in relative motion. (a) moving friction (b) static friction (c) lubricating friction (d) dynamic friction
4. Which of these drives involves positive transfer of motion? (a) gear drive (b) belt drive (c) chain drive (d) friction drive
5. Block moulding machine is an application of the --- (a) belt drive (b) gear drive (c) chain drive (d) sprocket drive
6. There are --- types of drives. (a) 1 (b) 2 (c) 3 (d) 4

ASSIGNMENT.

1. State two differences and two similarities between the belt drive and the chain drive
2. Mention two advantages of chain drive over the gear drive.

Period THREE:

- (a) Advantages of belt drives.
- (b) Disadvantages of belt drives.
- (c) Advantages of chain drives.
- (d) Disadvantages of chain drives.

ADVANTAGES/MERITS OF BELT DRIVES.

- (1) Used to transmit power at other/inclined angles.
- (2) They are easy to fix/design at any time.

- (3) Used where slip is important.
- (4) Friction is reduced.
- (5) No lubrication is required.
- (6) Used to transmit motion through a long distance.
- (7) Not much heat is generated.
- (8) It is not expensive.
- (9) Easy to serve and repair.

Disadvantages/Demerits of belt drives.

- (1) In large machines with large belt, slipping of belt can cause injury when in motion.
- (2) Belt wastes useful energy due to friction.
- (3) Excess heat produced due to friction in the belt can cause the belt to break.
- (4) It cannot transfer a heavy load.
- (5) It cannot do heavy work.
- (6) Due to excess heat produced by friction, belt has to be changed after a period of time.
- (7) Do not last long.

ADVANTAGES/MERITS OF CHAIN DRIVES.

- (1) Friction between the chain and the sprocket gear is minimal or little.
- (2) Chain does not break easily unlike belt drive since it is made of metal.
- (3) Chain drive is more reliable than belt drive since it doesn't allow slip.
- (4) Chain drives are narrower than belts making it easier to shift them from one gear to another in order to vary the gear ratio.
- (5) Chain drives are stronger than belts drive.

DISADVANTAGES/DEMERITS OF CHAIN DRIVES.

- (1) It requires lubrication to reduce friction.
- (2) It is not suitable for transmission of power at inclined angle.

- (3) it is unsuitable for transmission of energy over a long distance.
- (4) It has greater mass which increases the inertia/ driving force of the drive train.
- (5) It is prone to vibration because of the constant changes in radius of action during revolution.
- (6) It requires longer time to shut down.

EVALUATION.

- (1) State three merits of belt drive over chain drive.
- (2) List three advantages of chain drives over belt drives.
- (3) Itemize four demerits of chain drives.

WEEK END ASSIGNMENT.

- (1) State three disadvantage of belt drive over chain drive.
- (2) Give two examples in each case of the following:
 - (i) Belt drive mechanism
 - (ii) Chain drive mechanism.

CLASS: JSS TWO.

WEEK: 3 (THREE)

TOPIC: AIR FLOW, PNEUMATIC AND HYDRAULIC DEVICES.

CONTENT

- Air flow
- Bernoulli's principle
- Aerodynamics
- Definition of hydraulic and pneumatic devices.
- Examples of Hydraulic and Pneumatic devices.
- Components of the machines
- Working principle/operation of hydraulic and pneumatic device
- Uses of Hydraulic Devices
- Uses of Pneumatic Devices
- Advantages of Pneumatics Devices
- Advantages of hydraulic Devices

SUB-TOPIC ONE (1)

- Air flow
- Bernoulli's principle
- Aerodynamics

(a) Air flow

This refers to air molecules in motion. Flow is an exclusive property of all *fluids* (liquids and gases). However unlike liquids, air does not necessarily need a channel or container for it to flow. Breeze/wind is formed when molecules of air are set in motion. Molecules of air can be set in motion by any of the following processes:

- i. Blowing air
- ii. Using the bellows (often used by blacksmith)
- iii. Using pumps
- iv. Using fan

When liquids flow through channels, agents such as gravity or a mechanical device is necessary to sustain the flow. Liquid (water) flow could either be ***laminar (streamline)*** or ***turbulent***.

In **laminar flow**, all the portions of the water move gently in a path parallel to the confining channel.

Turbulent flow is a force flow; water particles do not move in a straight line. An example of this is the water flow in drainage during a heavy downpour.

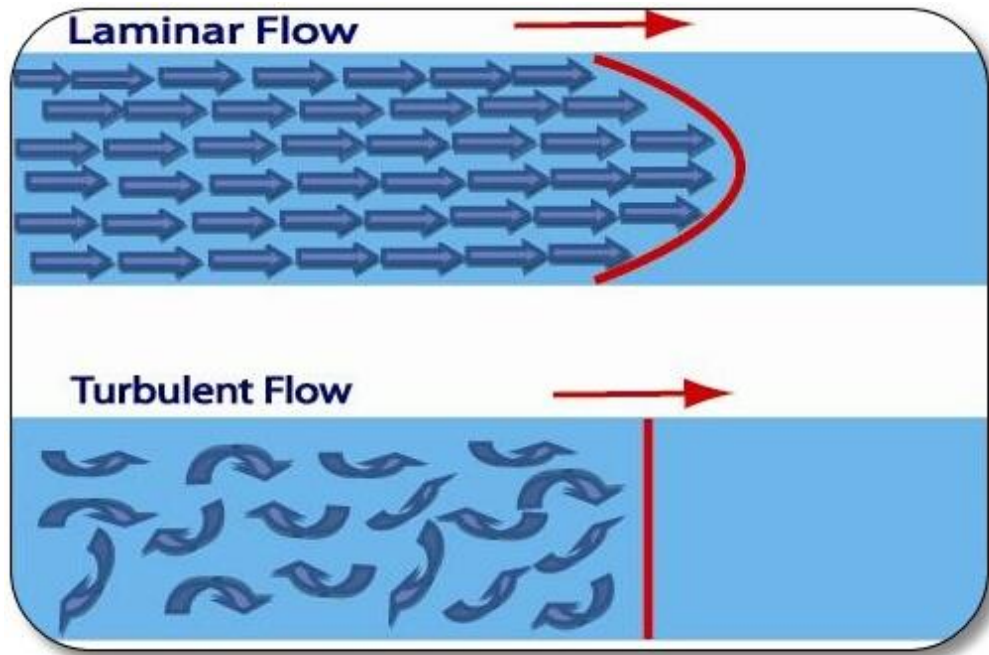

Moving air molecules possess energy. This energy can be applied in the following processes;

- Action of the wind mill

the wind mill



- Movement of flag attached to flag pole.



- Destructive action of the hurricane



When air moves over the surface of an object at high speed, the pressure on the surface is greatly reduced (i.e the faster air molecules move over a surface the lesser the pressure acting on the surface). This principle is called the **Bernoulli's principle**. This principle is used for explaining the lift force experienced by helicopters and aeroplanes when they are in air. To demonstrate this principle, you may try blowing air between two papers; you'll observe that the papers move toward each other instead of going apart. This is because increase in the speed of air between the papers result in decrease in the pressure between the papers.



A science that studies the force on object moving through air is called **Aerodynamics**.

Aeroplanes' wings are designed to have a streamline shape which allows the air above it to move faster than the air under it. The pressure under the aeroplane is therefore greater than that above the aeroplane thereby resulting in net pressure acting under the aeroplane as well as a lift force on the plane. The streamline shape of the aircraft also minimises the frictional drag force opposing the motion of the plane.

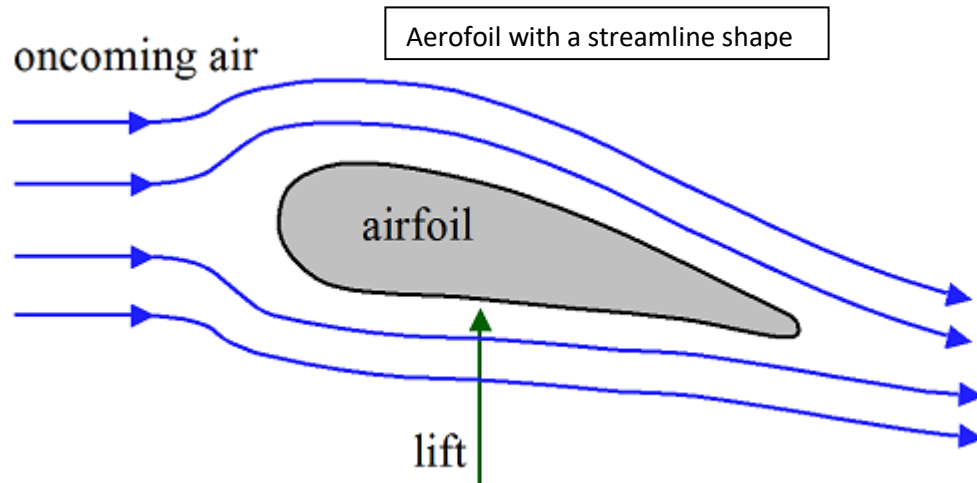

The drag force acts on the aeroplane in a direction perpendicular to the lift force.

Summarily, four forces act on a body moving through air:

- i. The weight(W) of the body which act downward
- ii. The lift force(L) which act upward
- iii. The drag force(D) which opposes the motion of the bodies

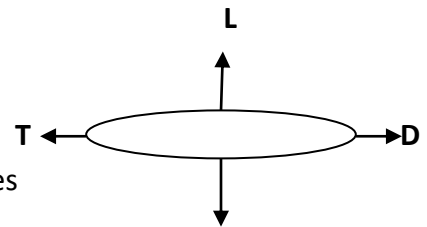

iv. The thrust(T) of body itself moving it forward

W

National Aeronautics and Space Administration



Airplane Parts and Function

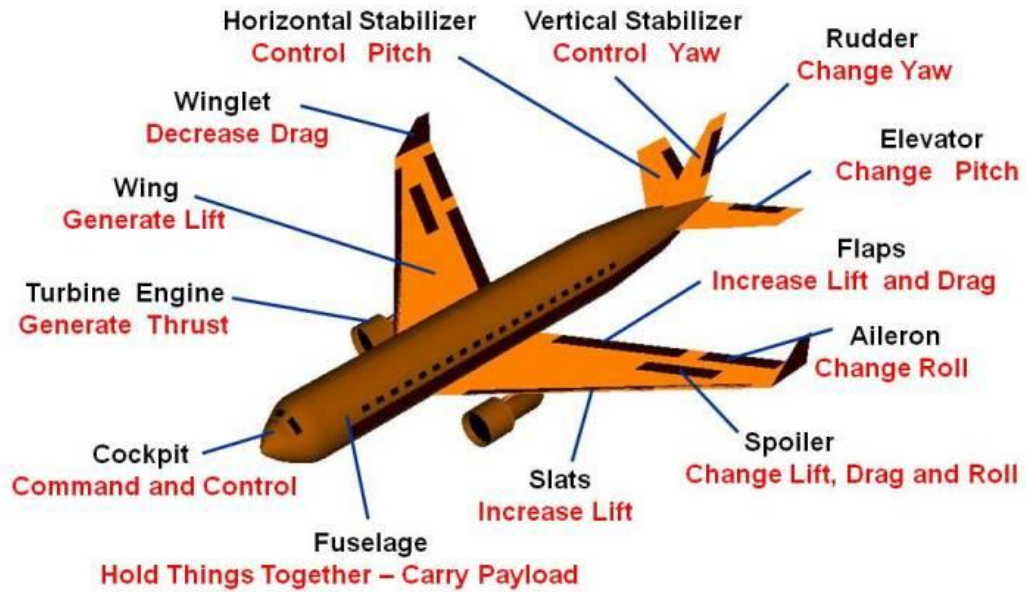

www.nasa.gov 16

Other applications of the Bernoulli's principle include;

I. Balloon



II. Kite

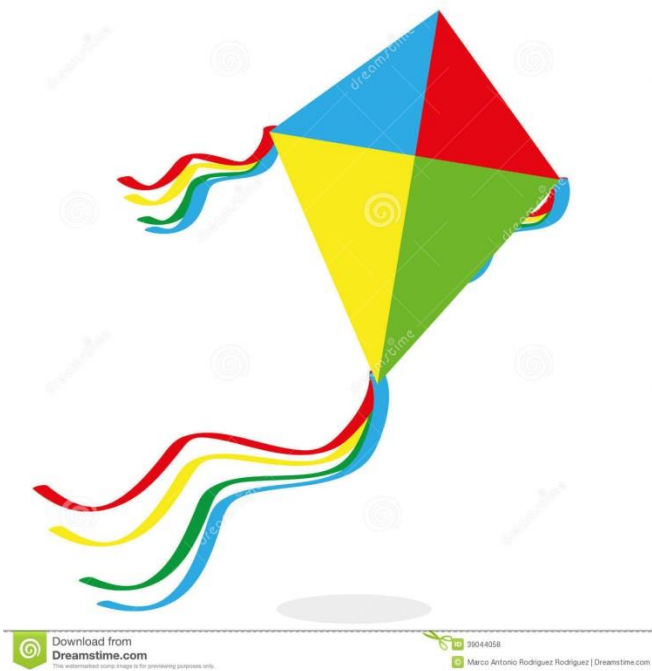

Evaluation

1. state the Bernoulli's principle
2. List the types of water flow.

SUB-TOPIC TWO (2)

CONTENT

(b) Hydraulic and Pneumatic Machines.

- Definition of hydraulic and pneumatic devices
- Examples of Hydraulic and Pneumatic devices
- Components of the machines

Hydraulic and Pneumatic devices

Hydraulic and pneumatic machines uses similar principle to operate, this principle is in the ability of water and air to expand immensely when subjected to pressure.

Hydraulic machines use water to operate, while pneumatic machines use air flow to operate. There are some among them that operate with use of both water and air.

Examples of hydraulic machines are:

- (i) hydraulic ram
- (ii) Garden sprinkler
- (iii) Water wheel
- (iv) hydraulic jack/ action
- (v) Turbines
- (vi) Hydraulic lift
- (viii) Force pumps

PNEUMATIC DEVICES

Examples of pneumatic devices are:

- (i) Bicycle Pump.
- (ii) Car foot pumps
- (iii) Pneumatic drills.(Jack hammer)
- (iv) Air compressor
- (v) Air hammer
- (vi) Compression pump.
- (vii) Paint sprayer
- (viii) Vacuum pumps.
- (ix) Simple force pump.
- (x) Centrifuge pump.

PNEUMATIC DEVICES.

These are devices that use compressed air to do useful work. Some of these devices also use liquids to transmit energy. Examples already mentioned above.

(c) Description and components of some examples of Hydraulic and Pneumatic devices.

(1) Water wheel

This is a simple mechanical device which converts water power into rotary motion. It is sometimes also called gravity wheel. Falling water is used to turn the axle of the water wheel.



water wheel

(2) Turbines

This is a rotary machine which converts the energy of moving water, steam or hot gas into mechanical energy.

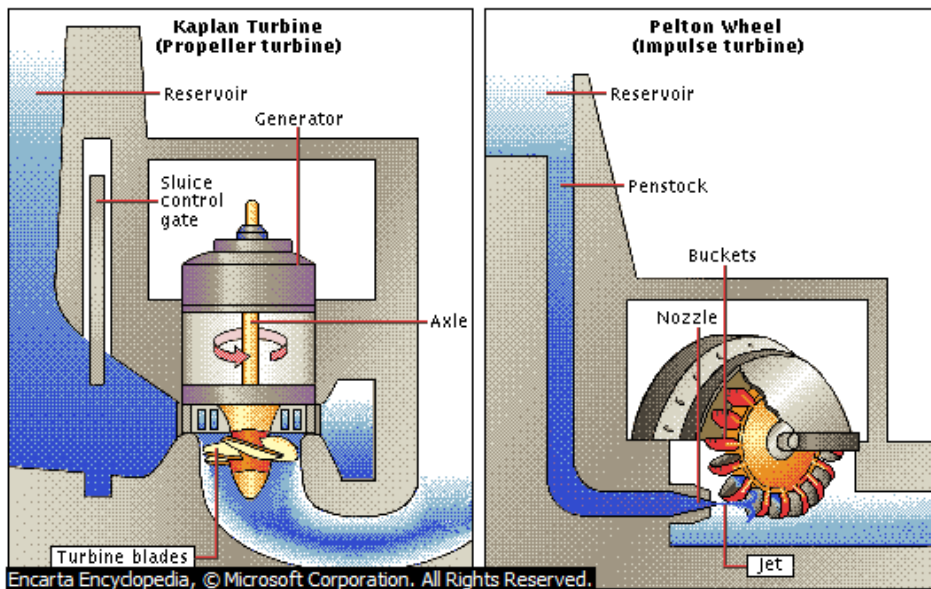

turbines

(3) Air Compressor

Air Compressor, also air pump is a machine that decreases the volume and increases the pressure of a quantity of air by mechanical means. Air thus compressed possesses great

potential energy, because when the external pressure is removed, the air expands rapidly. The controlled expansive force of compressed air is used in many ways and provides the motive force for air motors and tools, including pneumatic hammer, air drills, sandblasting machines, and paint sprayers.



(4) paint sprayer.

paint sprayer.



(5) Hydraulic lift

This applies the Pascal's principle of transmissibility of pressure to generate a huge force by applying a small effort.

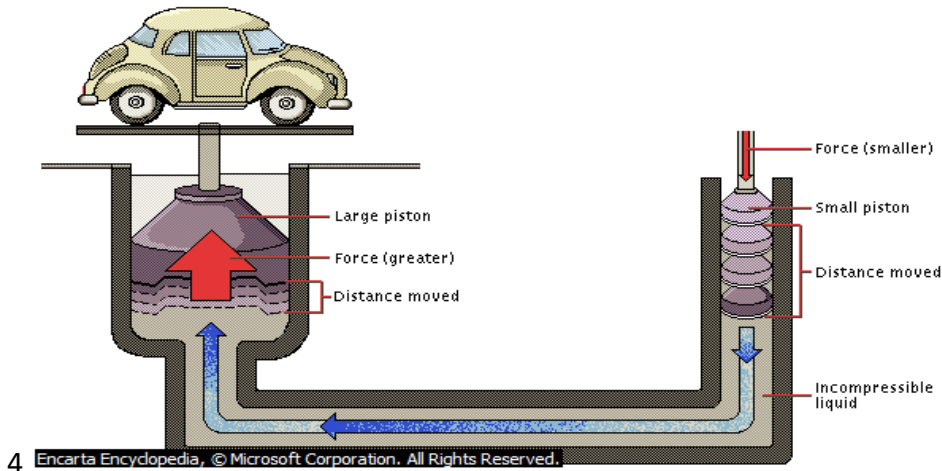

A small force can be used to lift a heavy car using the hydraulic lift. Many other hydraulic systems (e.g hydraulic press, hydraulic water pump, hydraulic jack...) also apply this principle.

(6) Garden sprinkler

This applies the Newton's third law of motion which states that for every action there is an equal but opposing reaction. When water is ejected from the nozzle of the sprinkler, the forward thrust of the water result in a backward push on the nozzle thereby making the sprinkler turn about it axis watering several portion of the garden and not just on a single spot.



EVALUATION

1. What are Hydraulic and pneumatic devices
2. Mention five types of pneumatic device.
3. Mention five components of the paint sprayer.
4. List three components of the hydraulic lift

ASSIGNMENT.

- (i) Explain the principles behind the working of pneumatic devices.
- (ii) Describe the working principles of hydraulic machine.

SUB TOPIC THREE (3)

- Working principle/operation of hydraulic and pneumatic device
- Uses of Hydraulic Devices
- Uses of Pneumatic Devices
- Advantages of Pneumatics Devices
- Advantages of hydraulic Devices

(a) PRINCIPLE BEHIND THE WORKING OF PNEUMATIC DEVICES.

The actual basis of hydraulic action or pneumatic devices is explained by Pascal's law on principle of transmissibility of pressure which states that " any change of pressure applied to the surface of a confined fluid or gas is transmitted unchanged to all parts of the fluid or gas.

A diagram below shows an hydraulic lift, having small and large piston for the transmission of fluid by the application of pressure. If piston X (small) has an area of 5cm^2 and a force of 50N is exerted on that piston, then the pressure is 1Pascal . This pressure is then transmitted through the pipe to piston Y (large), if piston Y has an area of 50cm^2 , then the area is ten (10) time great and the force exerted by the air inside the piston Y is therefore 10 time as great. The pneumatic machine uses these principles to carry a heavy load as shown in the diagram below.

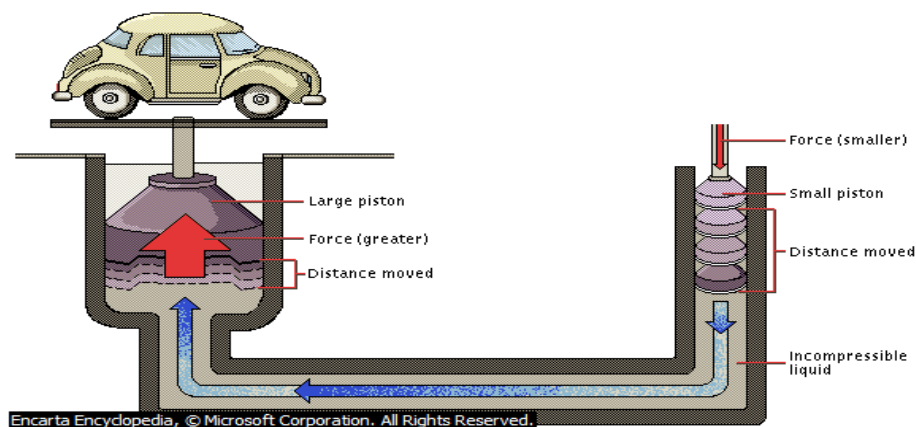

Hydraulic Lift.

(b) USES OF HYDRAULIC DEVICES.

- (i) Single force pump is used to push water, oil, gasoline, air from one pump of a pipe to another.
- (ii) Submersible pump is used to pump water from a well to an overhead tank.
- (iii) Hydraulic jack is used to lift a car up in order to change its tyre.
- (iv) Hydraulic ram is used to lift a car to a height convenient for an expert to work under the car.

(c) USES OF PNEUMATIC DEVICES.

- (i) Centrifuge pump is used to extract water from a working machine.
- (ii) Simple force pump is used to blow air into a bat balloon.
- (iii) Bicycle pump is used to pump air into type of a bicycle.

(d) ADVANTAGES OF PNEUMATICS DEVICES.

- (i) Cleanliness
- (ii) Simplicity of design and control.
- (iii) Reliability.
- (iv) Storage. (Compressed gas can be stored, allowing the use of machines when electrical power is lost).
- (v) It requires very little maintenance.
- (vi) Safety. (Very small fire hazards (compared to hydraulic oil)).

(e) ADVANTAGES OF HYDRAULICS DEVICES.

- (i) Fluid does not absorb any of the supplied energy.
- (ii) It is capable of moving much higher loads and providing much higher forces due to the incompressibility.
- (iii) The hydraulic working fluid is basically incompressible, leading to a minimum of spring action.

EVALUATION.

- (i) Mention three uses of hydraulic machine.
- (ii) Mention three uses of pneumatic machine.

ASSIGNMENT.

(i) Itemize four advantages of pneumatics devices.

(ii) State three merits of hydraulic devices.

WEEK: 4 (FOUR)

TOPIC: GEAR DRIVE

CONTENT:

- Gear drive
- Seizure
- Types of gears
- Uses of gear
- Power transmission.
- Changing direction,
- Selecting speed
- functions of lubricants in gears
- importance of applying lubricants to gears

SUB TOPIC ONE (1) Gear drive

This is a device used to transmit motion between parallel or inclined shafts that are close to each other (such that the tooth on the wheel mounted on the shafts mesh together). When two gears are in mesh, they are called **GEAR TRAIN**. Friction always occurs between the meshed teeth of the gear train. Constant lubrication is therefore necessary to prevent wearing. The teeth on each gear in mesh must be uniformly spaced around the gear (that is symmetrical) for them to mesh properly and to prevent damage of the tooth. Improperly meshed gears can also lead to *seizure* of the gear train.

Seizure is the total movement stoppage of the gear train.

Unlike the belt and the chain drive, the driver and the driven gear move in different direction. To make the driver and the driven gear move in the same direction, another gear (called the **IDLER**) is inserted between the two (driver and the driven gear).

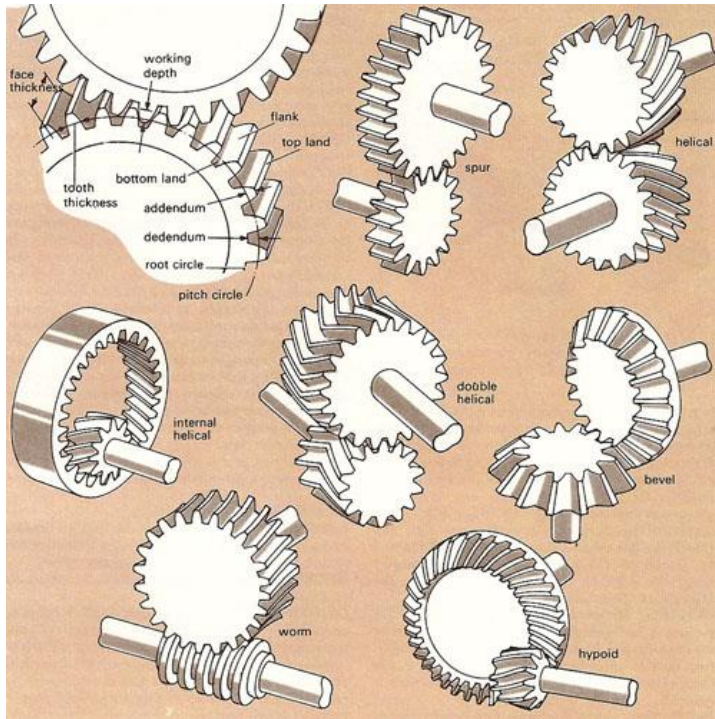

Types of gears

1. **Spur gear:** this has teeth parallel to the shaft of the gear.
2. **Helical gear:** this has teeth inclined to the shaft of the gear.
3. **Worm gears:** these are gears formed when a spur gear mesh with a screw.
4. **Rack and pinion:** these are gears that run on a flat toothed rack.
5. **Planetary gears:** these consist of a number of spur gear meshed with one another and another gear with internal gear.
6. **Bevel gears:** these are gears used when power is to be transmitted between inclined shafts



SPUR GEAR



HELICAL GEAR



BEVELLED GEAR

SPUR GEAR

HELICAL GEAR

BEVELLED GEAR

EVALUATION.

- (i) What is gear drive?
- (ii) Explain briefly the meaning of gear train.
- (iii) Describe briefly the functions of three types of gears.

ASSIGNMENT.

- (i) State four uses of gears.

SUB TOPIC TWO (2) Gear

- Uses of gear
- Power transmission
- Changing direction
- Selecting speed

Uses of gear drive

1. To transmit motion between two inclined or parallel shafts.
2. To change direction of motion.
3. For speed selection
4. Gears are used for transmitting power /drive between shafts at angles..

Gear ratio

This can be defined as the ratio of the number of teeth on the driver gear to that on the driven gear

$$G = \frac{T_1}{T_2}$$

T_1 is number of teeth on driver gear
 T_2 is number of teeth on driven gear

Speed ratio

This can be defined as the ratio of the speed of the driven gear to the speed of the driver gear.

$$S = \frac{S_2}{S_1}$$

S_1 speed of the driver gear
 S_2 is speed of the driven gear

The gear ratio and the speed ratio of a gear train are equal. The speed of rotation of the driven gear depends on the number of teeth on the driven and the driver gear. Where a large increase in speed is desired (like in the case of motor car), a **compound gear train** is used.

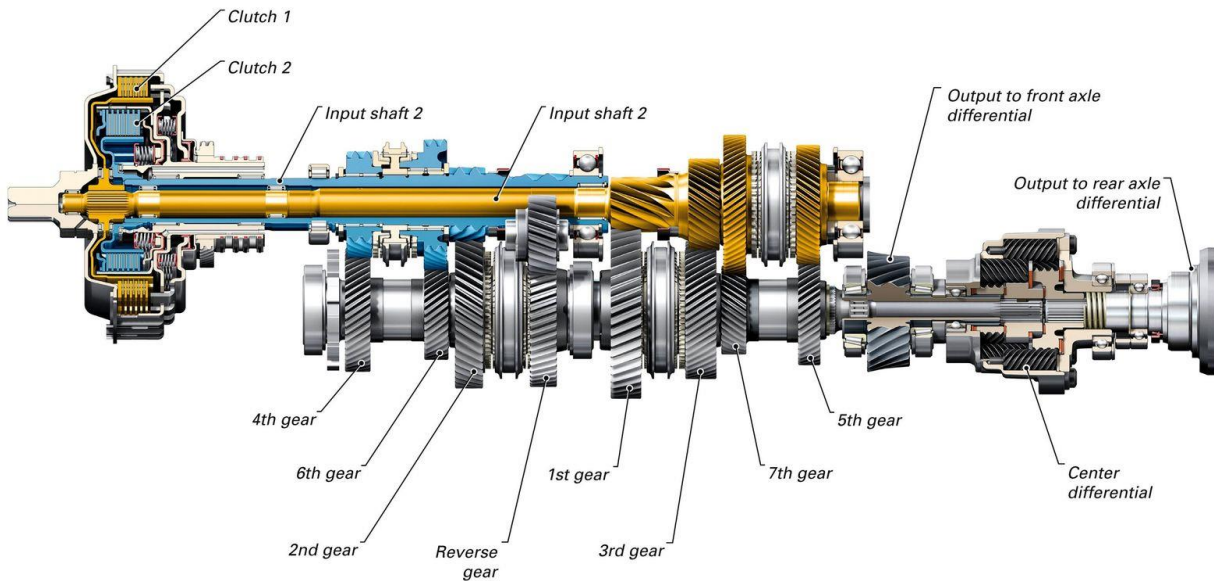

Compound gear

The speed of the driven gear S_2 is given as

$$S_2 = S_1 \times \frac{T_1}{T_2}$$

Where each symbols has it usual meaning.

Changing the direction of drive,

Chain drives cannot be used for changing the direction of rotation of drives. Belt drive cannot be used to change direction of rotation of drive except when belt is crossed. Gears can be used for changing the direction of motion. The **beveled gear** is often used for changing direction of motion between two perpendicular/inclined shafts.



EVALUATION

1. Which of these drives can be used to change the direction of rotation? (a) straight lap belt (b) chain drive (c) gear drive (d) none of the above

2. A gear with tooth parallel to the shaft is called ---(a) helical gear (b) planetary gear (c) worm gear (d) spur gear
3. The ratio of the speed of driver gear to the speed of the driven gear is --- (a) gear ratio (b) speed ratio (c) velocity ratio (d) none of the above

Answers

1. (c) 2. (d) 3. (d)

SUB – TOPIC THREE (3) GEAR RATIO AND GEAR SPEED

CALCULATIONS ON GEAR AND SPEED RATIO

Question 1: the number of teeth on the driver and the driven gear is 12 and 16 respectively. If the speed of the driver gear is 100rev/min, calculate (i) the gear ratio (ii) speed of the driven gear

Solution

Number of teeth on the driver gear $T_1 = 12$

Number of teeth on the driven gear $T_2 = 16$

(i) Gear ratio $G = ?$ $G = \frac{T_1}{T_2}$

$$G = \frac{12}{16} = 3/4$$

Gear ratio $G = \frac{3}{4}$

(ii) Speed of the driver gear $S_1 = 100\text{rpm}$

Speed of the driven gear $S_2 = ?$ $S_2 = S_1 \times \frac{T_1}{T_2}$

$$S_2 = 100 \times \frac{12}{16} = 75\text{rpm}$$

Speed of the driven gear $S_2 = 75 \text{ rpm}$

Question 2: A gear train is such that the number of teeth on the driver gear is 20 while that on the driven is 8. If the speed of the driver gear is 150rev/min. calculate the speed of the driven gear.

Solution

Number of teeth of the driver gear $T_1 = 20$

Number of teeth on the driven gear $T_2 = 8$

Speed of the driver gear $S_1 = 150\text{rpm}$

Speed of the driven gear $S_2 = ?$

$$S_2 = S_1 \times \frac{T_1}{T_2}$$

$$S_2 = 150 \times \frac{20}{8} = 375rpm$$

Speed of the driven gear $S_2 = 375rpm$

Question 3: in a compound gear train, the effective gear ratio is $\frac{16}{5}$. if the speed of the driver gear is 100rev/min, calculate the speed of the driven gear.

Solution

Speed of the driver gear $S_1 = 100rpm$

$$\text{Gear ratio } G = \frac{T_1}{T_2} = \frac{16}{5}$$

Speed of driven gear $S_2 = ?$

$$S_2 = S_1 \times \frac{T_1}{T_2}$$

$$S_2 = 100 \times \frac{16}{5} = 320rpm$$

Speed of the driven gear $S_2 = 320rpm$

Question 4: A gear train has a gear ratio of $\frac{5}{2}$ and a driven gear rotating at a speed of 180revolution per minute. What would have been the speed of the driver gear?

Solution

Speed of the driven gear $S_2 = 180rpm$

$$\text{Gear ratio } G = \frac{5}{2}$$

Speed of the driver gear $S_1 = ?$

$$S_2 = S_1 \times \frac{T_1}{T_2}$$

$$180 = S_1 \times \frac{5}{2}$$

$$180 = \frac{S_1 \times 5}{2}$$

$$180 \times 2 = S_1 \times 5$$

$$S_1 = \frac{180 \times 2}{5} = 72 \text{ rpm}$$

Speed of the driver gear $S_1 = 72 \text{ rpm}$

Practical

The teacher should guide the students on how to use a hard cardboard to construct gear with uniform tooth with the aid of the construction tools.

Using hard cardboard gear of different radii and their centres with nail at different portion on a wood, the students should demonstrate the operation of compound gear.

Evaluation question

1. Which of these gears is a combination of a spur gear and a screw? (a) bevel gears (b) helical gear (c) spur gear (d) worm gear
2. A condition in which the movement of a gear system is halted due to a spoil is known as ---- (a) slip (b) seizure (c) reverse (d) bevel
3. The friction between the teeth of meshed gears can be reduced BY (a) avoiding the use of gear (b) exposing gear to air (c) Lubrication (d) aeration
4. The major use of drive is to (a) transmit motion (b) change direction of motion (c) reduce speed (d) avoid friction
5. The ratio of the number of teeth on the driven gear to the number of teeth on the driver gear is called (a) speed ratio (b) gear proportion (c) gear ratio (d) none of the above
6. The gear ratio of a gear train is $\frac{7}{4}$ and the speed of the driver gear is 80rpm. What is the speed of the driven gear? (a) 70rpm (b) 140rpm (c) 150rpm (d) 210rpm

ASSIGNMENT

1. Consult your textbook and make a list of ten types of gear.
2. List five applications of the gear drives

FUNCTIONS OF LUBRICANTS IN GEARS

The main purpose of lubrication is to reduce friction and wear. Where friction is not wanted, it is desirable to reduce its effect to a maximum. This is done by separating solid surface out of effective contact with each other. In order to achieve this, a lubricant is introduced between the two surfaces.

Oil or grease which offers little resistance to motion is usually employed in a thin layer. This film of oil or grease separates the two surfaces. The film of oil reduces effective contact of the surface and reduces resistance to motion.

IMPORTANCE OF APPLYING LUBRICANTS TO GEARS

- (i) lubricant prevents the gear surfaces from corrosion.
- (ii) Lubricant prevents wear and tear of moving parts.
- (iii) It reduces frictional effect.
- (iv) Lubricant serves as a cooling agent to reduce the heat generated.
- (v) It serves as cushion for the machine by filling the space between metal parts.

EVALUATION

- (i) What is lubrication?
- (ii) Mention two lubricants for gears.
- (iii) State three importance of lubricants to gears.

SUB-THEME: PROCESSING OF MATERIALS

WEEK FIVE (5)

TOPIC : WOOD

CONTENT:

1. Production of Wood Materials, Timber Growth and Felling.
2. Properties of good timber preservatives.
3. Common timber defects, twist, bowing, cupping, etc
4. Methods of cutting veneers

Sub-Topic 1: Production of Wood Materials, Timber Growth and Felling.

Wood is one of the oldest materials in technology. It is composed of cellulose, lignin and other minor materials such as starch, resins, wax and gum. When closely observed, wood is seen to be made up of tiny thread-like units called fibers.

Wood is classified as either hardwood or softwood. The older the tree, the bigger it becomes. When the trees become mature, it is felled by the use of axe or chain saw and sliced into standard market sizes for different purpose in furniture making and construction of buildings.

Hard Wood: These are got from deciduous tree. They have broad leaves and their seeds are enclosed in cases. Some examples include Mahogany, Afara, Opepe, Abura, Omo, Agba, Sapele, Oak, Jarrah and Teak.

Soft Wood : These are got from coniferous trees (i.e. trees that bear naked seeds which are in cones). They have narrow leaves and grow in the temperate regions of the world. Examples include cedar, pine, fir, larch, spruce and European whitewood.

Examples are:

S/n	Trees	Colour identification
1	Iroko	Yellowish brown
2	Mahogany	Reddish brown
3	Afara	Pale-colour
4	Teak	Red-brown
5	Yew	Dark- green
6	Cotton- wood	Grayish white to light grayish brown
7	Hickory	Reddish brown

Tree Growth: Trees undergo two types of growth:

1. Primary or vertical growth. This takes place mainly near the tips of the root and shoots of the tree and continues for the most part of the plant's life.
2. Secondary or horizontal growth. This results in increase in girth and takes place mostly in the cambium.

The stages of processing wood before becoming useful are:

- i. Felling
- ii. Conversion
- iii. Seasoning
- iv. Preservation.

TYPES OF TREE:

- Deciduous Tree = Hard wood
- Coniferous Tree = Soft wood

THE MAIN PARTS OF A TREE.

- 1) The Roots
- 2) The Stem / Trunk
- 3) The branches
- 4) The bark

5) The Leaves

Parts of the Tree

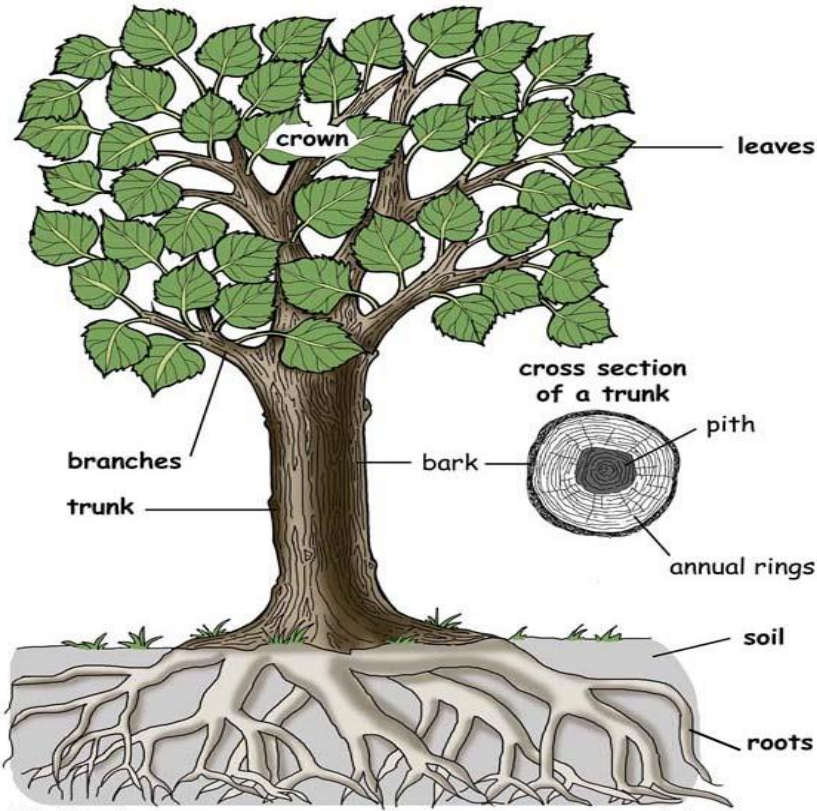

©Sheri Amsel

www.exploringnature.org

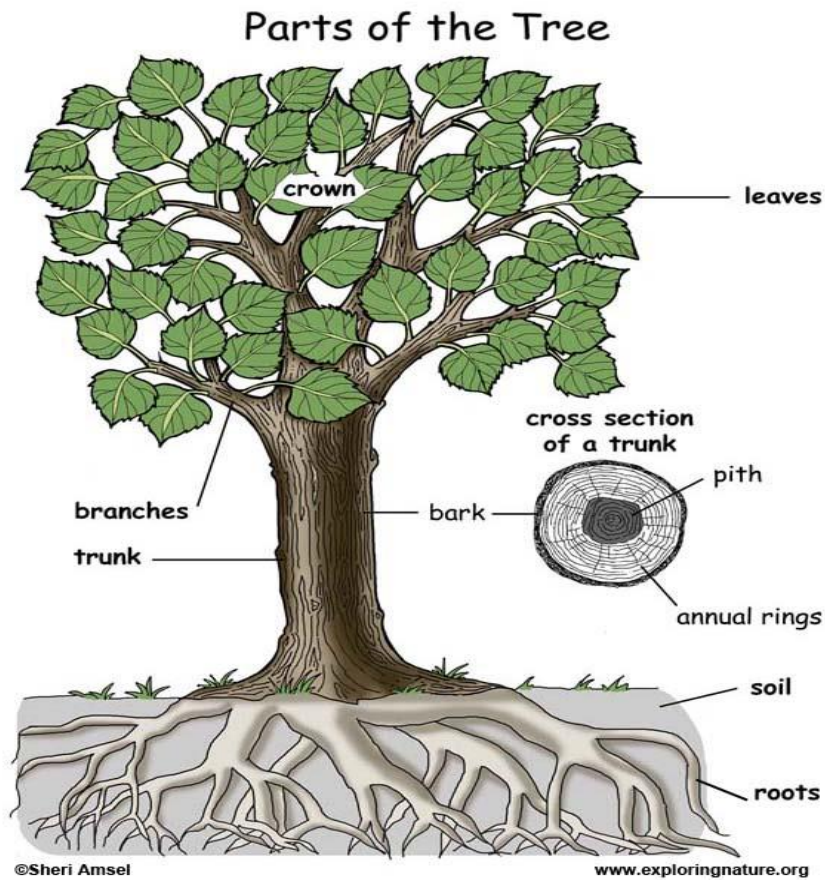

The felling of trees for timber use is done broadly in two areas in Nigeria.

- I. The Free Area
- II. The Forest Reserve Area.
 1. **The Free Area:** This is the area outside the forest reserve area and it is owned by individuals. The amount of money paid to the government by the timber contractor for permission to cut down any tree in the Free Area for commercial purposes is called Tariff.
 2. **The Forest Reserve Area:** This is the government owned area. The forest reserved area is guarded by the forest guards. Hence, it is difficult for anybody to cut down any tree in the forest reserve area without the permission from the government. The amount of money paid for the timber to be cut down in the forest reserve area depends on the volume of the trees to be cut down. Hence, this is termed O.T.V i.e Out Turn Volume.



The portable powered saw used in cutting down trees is called Chain saw.



METHODS OF TRANSPORTING LOGS.

Logs are transported from the forest to sawmill, where they are sawn into the required lengths and sizes of planks. Methods of transporting logs are:

- I. By Road Transport



II. By Train



III. By Waterways.



CONVERSION OF WOOD.

The conversion of wood is the process of sawing logs of timber with wood working machines (Sawing machine) in the Sawmills into planks of required size or marketable size or commercial sizes. The popular methods of conversion of logs of timber into planks are:

- I. The plain (through and through) method
- II. The quarter sawn method
- III. The tangential sawn method

1. **Plain Sawn Method:** The plain sawn method is also known as through and through method. In plain sawn method, planks are sawn parallel to the axis of the tree trunk. This method of sawing planks is used for producing planks which are needed for doors, windows and roofs of houses. The planks are cut parallel to the axis of the wood.

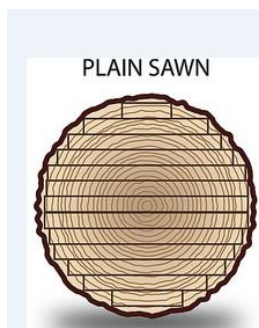

2. **Quarter Sawn Method:** This method is simply the sawing of timber plank after plank. The Quarter sawn method is the method of conversion of timber along the rays of the wood. In quarter sawn method, planks are cut at right angles to the growth rings. This method of sawing planks is used for producing planks which are cut with the growth rings running through the thickness of the planks.



Tangential Sawn Method: Tangential sawn method of sawing planks in which the planks are cut so that their wide edges are tangential to the growth rings.

Tangential sawn

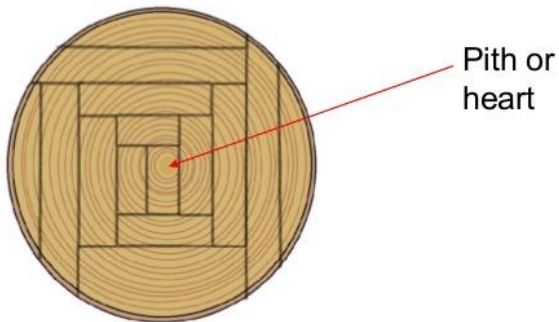

Some of the machines used for conversion of trees are:

- a) The circular saw
- b) The horizontal log band saw
- c) The vertical log band saw
- d) The frame saw.

SEASONING OF WOOD.

Wood contains a great deal of water. The water content must be reduced by a process known as seasoning before the wood can become useful. Seasoning of wood is the process of drying or reducing the excess water in the wood. The excess water is called moisture content.

Methods of seasoning wood:

There are two methods of seasoning wood.

1. The Air seasoning(Natural Seasoning)
 2. The Kiln Seasoning (Artificial Seasoning)
1. **The Air Seasoning:** This is also called Natural seasoning. This method of seasoning wood involves stacking the wood in the open shed for a long period of time and allows it to dry naturally. The stacked planks (wood) are arranged on top of one another with pieces of small wood called **stackers** in between them in order to allow the free circulation of air.

Advantages:

- It is relatively cheap.
- It requires little attention

Disadvantages:

- The rate of drying is slow, so it takes a very long time to be seasoned.
- There is no control over the drying process.

Air Seasoning

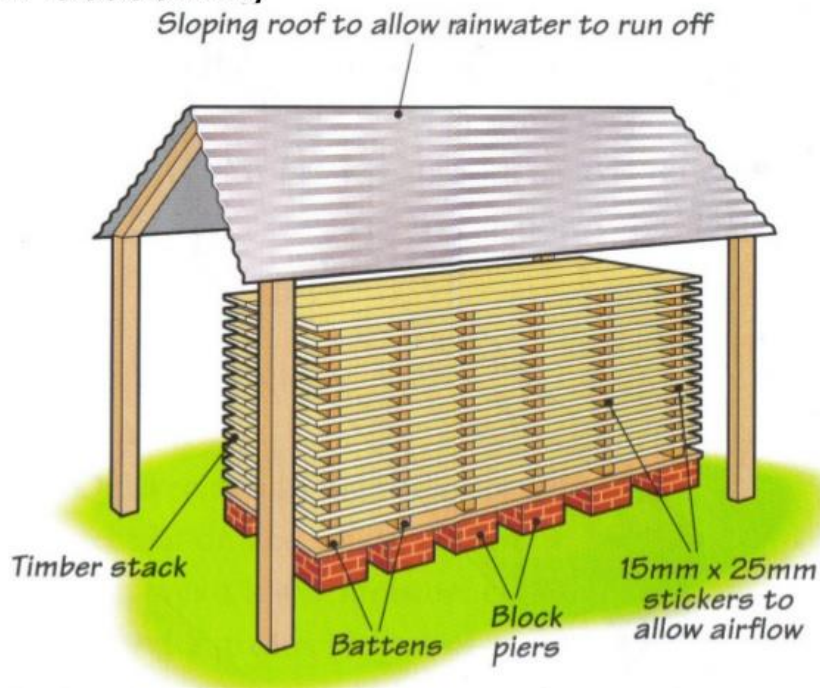

2. **The Kiln Seasoning:** This method of seasoning wood, involves stacking the timber in a specially heated chamber. The planks are stacked in the same way as in the air seasoning, but the planks are placed in a specially heated chamber called **kiln**. In this process, the rate of drying planks is faster than air seasoning method.

Kiln seasoning

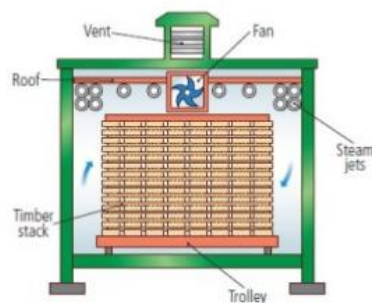

- Advantages
 - Dries more quickly
 - Final moisture content is lower
 - Can be properly controlled.
 - Defects associated with seasoning are minimised
- Disadvs.
 - Heating the kiln uses a lot of energy
 - It is an expensive method
 - Requires a skilled operator

REASONS FOR SEASONING WOOD

1. It makes the wood become lighter in weight.
2. It makes the wood become more stable.
3. It makes the wood to take paints, polishes and preservatives easily.
4. It makes the wood to be durable i.e. last longer
5. It reduces the attack of fungi and insects on wood.
6. It reduces the moisture content of the wood.

To calculate the moisture content present in the wood:.

$$\text{M.C} = \frac{\text{Wet weight} - \text{Dry weight}}{\text{Dry weight.}} \times \frac{100}{1}$$

Example 1

A sample of wood weighs 70kg when wet and after seasoning weighs 40kg. What is the percentage moisture content?

Solution:

$$\text{M.C} = \frac{\text{Wet sample} - \text{Dry sample}}{\text{Dry sample}} \times \frac{100}{1}$$

Wet sample= 70kg

Dry sample= 40kg

M.C= ?

$$\frac{70 - 40}{40} \times \frac{100}{1}$$

$$\frac{30}{40} \times \frac{100}{1}$$

M.C = 75%

Class work.

1. The weight of sample of wood before drying was found to be 120kg. The percentage moisture content was found to be 50%, what is the weight of the sample of the wood after drying?

Answer= 80kg.

2. The weight of a sample of wood after drying was found to be 60kg. The percentage moisture content was 40%, what is the weight of the wood before drying?

Answer= 84kg.

Sub-Topic: 3

Common Timber Defects

Defects in timber

A defect in timber is any feature in timber that reduces the quality and the market value of the timber.

Types of defects in timber.

Defects in timber can be grouped into two types:

- I. The Natural defects
- II. The Artificial defects.

THE NATURAL DEFECTS:

The Natural defects in timber are those defects that are caused by natural occurrences such as thunder, rain, growth circumstances etc. Examples of natural defects are:

Shakes : These are disruptions in the wood fibre which show up as splits and separation of parts of the stem of a tree.

Examples:

Heart shakes: This is visible on the cross-section of the centre of the log, extending along the rays

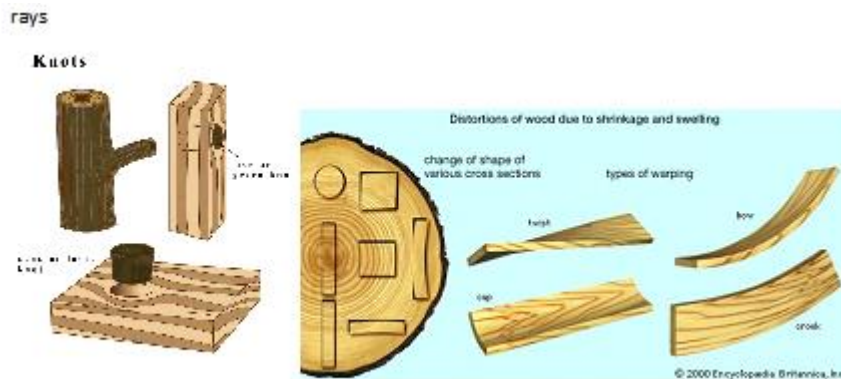

Star Shakes: This is similar to the heart shake, but with more splits like star.

Cup Shakes: These are visible cracks which go round the growth ring of the wood.

Ring Shakes: These are circular cracks on the timber.

Knot: knots are caused by branches.

THE ARTIFICIAL DEFECTS:

The artificial defects are those defects that are caused by human beings through careless handling of the wood while processing.

Examples :

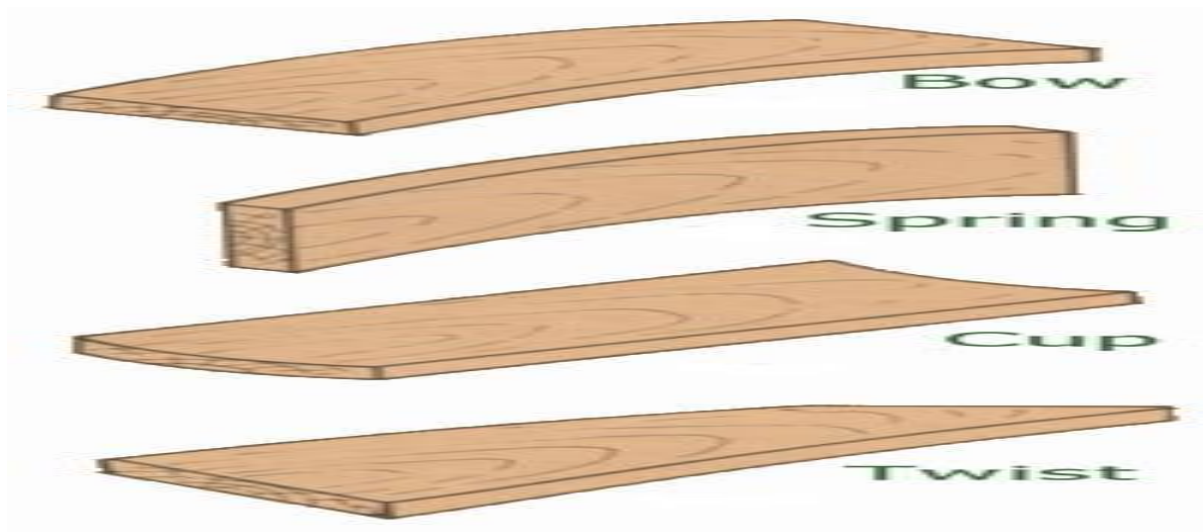
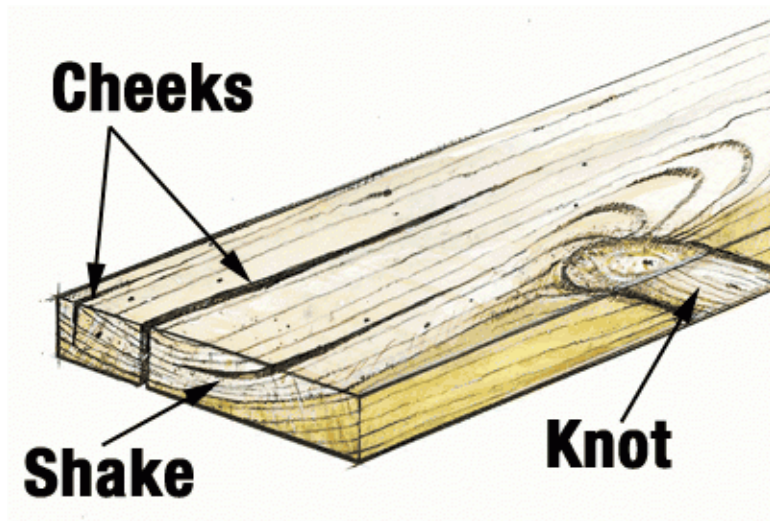

- Cup: This is the concave curvature across the face of the timber.
- Bow: This is either concave or convex curvature along the length of the plank.
- Check: This is the separation of the wood along the grains of the wood.
- Twist: This is the spiral form of distortion along the length of the plank.
- Insect Attack: This is the visible minute holes seen on the surface of the wood. The insects always attack sap wood.
- Warps: The warp in timber is called twists. They are caused by improper seasoning procedures of wood fibers.

WEEK 6

Sub-Topic:

- Veneers
- Types of Manufactured boards – plywood, chip board, block board, etc.
- Timber treatment and timber preservation methods.
- Importance of timber treatment.

Sub-Topic 1 Veneers

Veneers : A veneer is a thin layer of sliced sheet obtained from wood. The thickness of the veneers ranges from 0.5mm – 3.0mm



Method of making veneers

1. Rotary method
2. Slicing method
3. Eccentric method

- 1. Rotary Method.** The rotary method requires the wood to be steamed in order to loosen the fiber and make it easy to peel with knives attached to the lathe machine. With the lathe machine, large sheets of veneers can be produced and cut to marked sizes for commercial purposes.

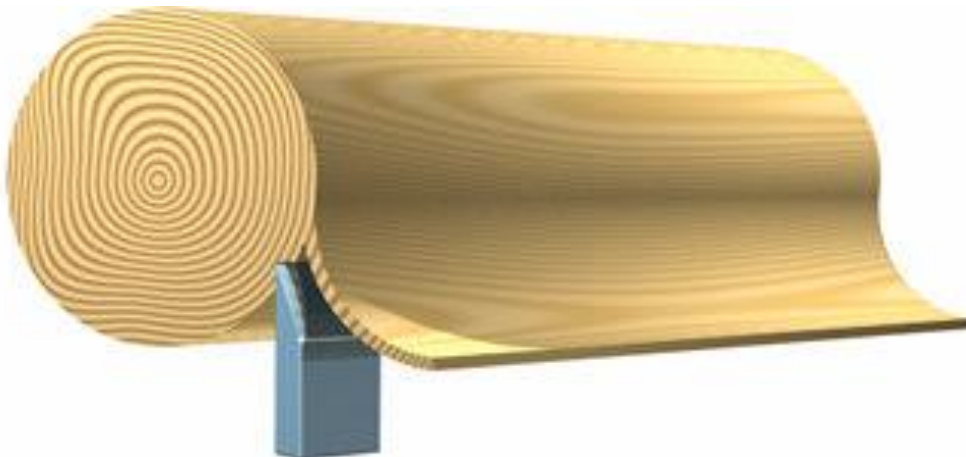

- 2. Slicing Method.** The timber is safely attached to the slicing machine. The knife or the cutting blade on the machine will be set on the wood depending on the thickness of the veneer required. The thickness is set after every stroke. On switching on the machine, it slices the sheet of wood to the required thickness depending on the purpose of the veneer.



- 3. Eccentric Peeling.** In eccentric peeling method the log of wood is first cut into four parts each of which is called quarter log. Each log is placed on the lathe machine with the sapwood at the centre. The peeling of the veneer commences from the heartwood to the sapwood.

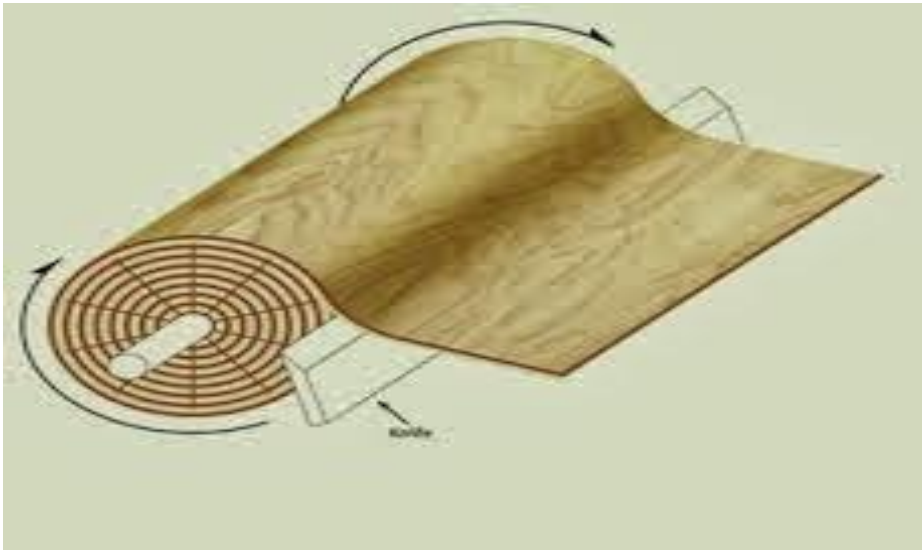

Types and Manufacture of Laminated Boards

Laminated boards are manmade boards manufactured by man from veneers, wood waste, synthetic and impregnated paper bonds. Types and methods of manufacture of laminated boards are as follows;

1. Examples of Man-made boards.
 - I. Plywood



II. Particle board



III. Laminated board



IV. Chip board



V. Composite board



VI. Pattern board



VII. Block boards

Ply wood



Plywood is produced by bonding three or more veneers together with strong glue. The grain of each sheet of veneer is laid at right angle to each other. After successfully bonding the sheets of veneers

together, they are cut in different sizes for commercial purposes such as 2440mm X 1220mm with thickness, ranging from 1 to 25mm.

1. **Chipboards:** Chipboards are produced with wood chips. The chips which are wastes from wood are mixed with glue. After mixing thoroughly with glue they are pressed together and heated to form boards. The boards can be veneered to form smooth surfaces. Chipboards can be used in the construction of kitchen cabinets.
2. **Blockboards:** Blockboards are made of strips of wood placed side by side and covered with veneers. It is similar to plywood. But it is thicker, stronger and cannot be bent easily. They can be used in the construction of different types of cabinets including tables, cupboards and room dividers.
3. **Hardboards:** They are manufactured from waste wood mixed and mashed with hardeners and bonding materials like glue. After mixing with glue or any other bonding material they are pressed with great pressure and high temperature. Hardboards can be faced with veneer, enamel and plastics.
4. **Laminated Plastics:** They are manufactured from synthetic resin and impregnated paper. The materials are bonded together with great pressure and heat is applied. Laminated plastics do not allow the passage of water through them. They are strong and durable.

ADVANTAGES OF MANUFACTURED BOARDS

Manufactured boards have the following advantages over solid wood.

- i. They are available in flat large sheets.
- ii. They can be cut easily and worked on.
- iii. They can be easily nailed without splitting.
- iv. They can be bent to form curves.
- v. They do not check or warp like solid wood.

EVALUATION:

- 1) What is conversion of timber?
- 2) Mention three methods of conversion of timber.
- 3) Define seasoning.
- 4) Give three advantages of seasoning.
- 5) Mention five defects in timber.
- 6) List five properties of good wood preservatives.

Treatment and timber preservation

This is the process of prolonging the life span of wood by the application of wood preservatives.

Wood preservatives are applied to the planks to prevent insect and fungal attack.

Wood Preservatives: These are the chemicals used to poison the destructive agents in the wood. E.g. fungi, insects, and termites. Some of the chemicals used as the wood preservatives are solignum, creosote, phenols, paints etc.

Types of wood preservatives: There are three major types of wood preservatives depending on the method of mixing.

1. Water soluble preservatives: These are the chemicals that can be mixed thoroughly with water only.
2. Oils soluble preservatives: These are the chemicals that can be mixed thoroughly with oils only.
3. Solvent soluble preservatives: These are the chemicals that can be mixed thoroughly with evaporating liquids only.

Methods of Applying the Preservatives:

The methods of applying good preservatives to dry wood are:

- i. **Brushing Method:** This is the process of using brush to apply preservatives to the wood.
- ii. **Spraying Method:** This is the process of using spraying gun to apply preservatives to the wood.
- iii. **Cold Immersion Method:** This is the method of immersing (dipping) planks in an unheated solution of preservatives for one or two days.
- iv. **Open Tank Method (Hot and Cold Method):** This is the process in which the plank is immersed in a tank containing hot liquid preservatives. This process is normally used for Treating poles and fence posts.
- v. **Pressure Treatment Method:** This is process in which planks are placed inside an enclosed metal cylinder. In the process, the preservatives are being forced into the plank under high pressure. This enables the wood to be preserved either by pumping the solution into the entire cell cavity or by merely coating the cell wall with the preservatives and finally draining the cell cavity, leaving the cell saturated with preservatives, when the process is completed.

Properties of Good preservatives:

The following are the properties of good preservatives:

- I. It must be poisonous to the destructive agents.
- II. It must be safe to handle
- III. It must be permanent to the wood on application
- IV. It must be easy to apply on the wood
- V. It must be chemically stable for a long time on application to the wood.

WEEKEND ASSIGNMENT:

1. Draw a growing tree and label its parts.
2. State the function of each part labeled in (1) above.
3. Give three advantages of manufactured boards over solid wood.
4. Read your textbook 'Basic Technology for Junior Secondary School', By P.O Olawehinmi. Pgs 134-136 Study the topic 'Production of Metallic Materials' against the next lesson.

WEEK SEVEN: MID TERM BREAK

WEEK EIGHT: PROCESSING OF MATERIALS

TOPIC: METALS

CONTENT:

- Production of metals: smelting, casting, etc.
- Carbon properties of steels
- Metal Alloys
- Clay, ceramics and glass

Metallic materials are materials which are referred to as good conductors of heat and electricity. Metals are gotten from Iron ore which is the raw material for metal production. The Iron Ore is dug from the ground along with the impurities (coke, hot air, limestone with Iron Ore).

When the Iron Ore is dug up from the ground, it cannot be used as it contains some impurities, it undergoes certain processes during which these impurities are removed and other substances are added. Since these impurities cannot be removed from iron-ore in its solid state, it is converted into a liquid state by heating. Thus process is known as **smelting**. The equipment used for this process is called a **furnace**. After removing these impurities from Iron Ore, the product left is called **Pig-Iron**. The Pig iron in its ordinary state cannot be used without further processing; this is because pig iron contains saturated iron and carbon. This is weak and can break easily. Hence, it forms the basis of all ferrous metals containing about 45% carbon.

In order to render pig iron usable such as cast Iron, steels and wrought Iron, the amount of carbon it contains must be reduced.



1. **Cast Iron:** This is obtained when pig Iron is put into a cupola furnace. In this furnace, the carbon content is reduced to about 3.5%. The molten Iron is then poured from the furnace into a container, called mould, so as to solidify it. This process of pouring molten iron into a mould to solidify into a described shape is called casting, hence, the name cast iron.

Examples of cast iron

- i. Ductile (chilled) cast iron
 - ii. Malleable cast iron
 - iii. Grey cast iron
 - iv. White cast iron.
2. **Steel:** This is obtained when the carbon content of pig iron is reduced to 1.5 or less. Steels are named according to the carbon content present in them. These steels are called **Plain Carbon Steels** because they are made up of carbon and iron.
 - I. Low carbon steel: (mild steel) this contains about 0.3% or less of carbon.
 - II. Medium carbon steel: This contain between 0.3%- 0.5% of carbon.
 - III. High carbon steel: This contains between 0.6%- 1.5% of carbon.

Furnaces used are open hearth and Bessemer converter.

3. **Wrought Iron:** The wrought iron is obtained by removing the carbon content present in the pig iron. It is soft, easily bent and does not break or rust easily. This is almost pure iron with little slag on it. The wrought iron has no carbon content in them. It is almost rust proof. It is malleable and ductile and can be easily forged into the required shape. Wrought Iron is used in the manufacture of chairs, boilers, plates, gears and so forth.

Casting: This is the process of melting and pouring molten metal into the mould where it cools down to solidify.

Smelting: This is the process of extracting metals from its iron-ore to a liquid state by heating. In this process, all impurities are extracted from the Iron- Ore to form pig-iron.

Annealing: This is the process by which metals can be softened.

Alloy steels

All steels are alloys because they contain both iron and carbon. Alloy steel is a combination of plain carbon steel and one or more other elements which are placed in the electric furnace and then heated. This molten mixture is then poured into a mould container and then cooled to solidify. The alloy steels are:

- I. **High tensile steels:** This is also known as Nickel - chrome alloys. These contain iron, carbon, nickel and chromium. They are used for making machine parts which require high tensility and strength.
- II. **High Speed steels:** These contain iron, carbon, tungsten and chromium. Other forms of high speed steels contain cobalt and vanadium. They are used as cutting edges in machines where friction causes excessive heat due to continuous cutting.
- III. **Stainless steels:** These contain Iron, carbon, Nickel or chromium. Nickel and chromium are principally used as coating for the metals so as to make it resistant to corrosion. They are produced in electric furnace.

PROCESSING OF NON-FERROUS METALS:

The non-ferrous metals are the metals which do not have iron content in them, therefore they are not magnetic.

Examples: Copper, Aluminum, Zinc, Gold and Tungsten.

Iron ore is loaded into a furnace and then melted. The desired metal in a molten state is then separated from the mixture. The molten metal is then poured into containers so as to solidify. When this is done on a large scale, a reverberating furnace is used. The furnace is built of clay or other suitable earthen materials and further reinforced with steel on its outer walls.

Kiln furnace

A furnace is a solid structure in which a lot of heat energy is generated to produce metal. The different types of furnaces in which different types of metals are produced are:

Blast furnace: This is the structure used for producing pig-iron from Iron Ore.



Bessemer converter: This is the structure used for producing steel from pig iron.



Open hearth furnace: This is the structure used for producing steel from pig-iron.



Electric Arc-furnace: This is the structure used for producing stainless steel.

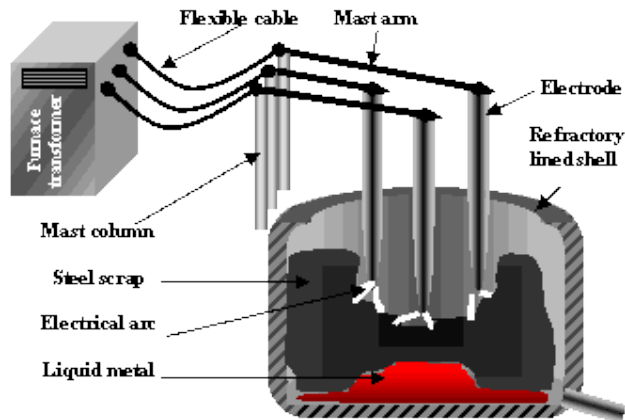

Cupola furnace: This is the structure used for producing cast iron from pig-iron.

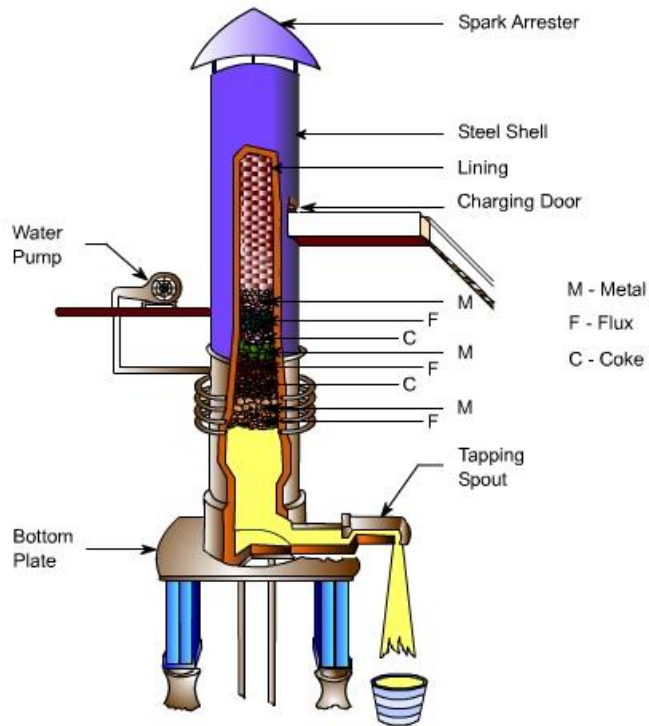

Pudding furnace: This is the structure used for producing wrought-iron.

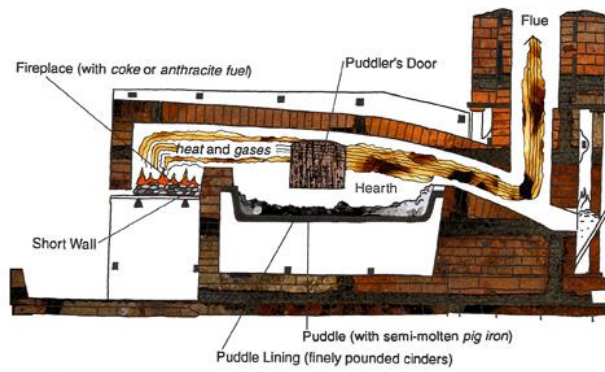

Fig. 9 Diagram of a rolling-mill puddling furnace.

Reverberating furnace: This is the structure used for producing non-ferrous metals.



Sub-Topic: 2 Metal Alloy.

An alloy is a mixture of two or more metals. A non-ferrous alloy is a mixture of two or more non-ferrous metals.

Examples of non-ferrous alloys are Brass, Bronze, Soft Solder, Duralumin, etc.

- i. Brass: Brass is a mixture of copper and zinc
Brass= copper + Zinc
- ii. Bronze: Bronze is a mixture of copper, Tin and Phosphorus.
Bronze = Copper + Tin + Phosphorus
- iii. Soft solder:
Soft solder = Lead + Tin
- iv. Duralumin: Duralumin is a mixture of copper, Aluminum and Magnesium
Duralumin = Copper + Aluminum + Magnesium.

Forms of metals.

- 1) Bars
- 2) Wires
- 3) Sheets
- 4) Rod
- 5) Pipes
- 6) Plates
- 7) Tubes
- 8) Channels.
- 9) Square/ Triangular metals

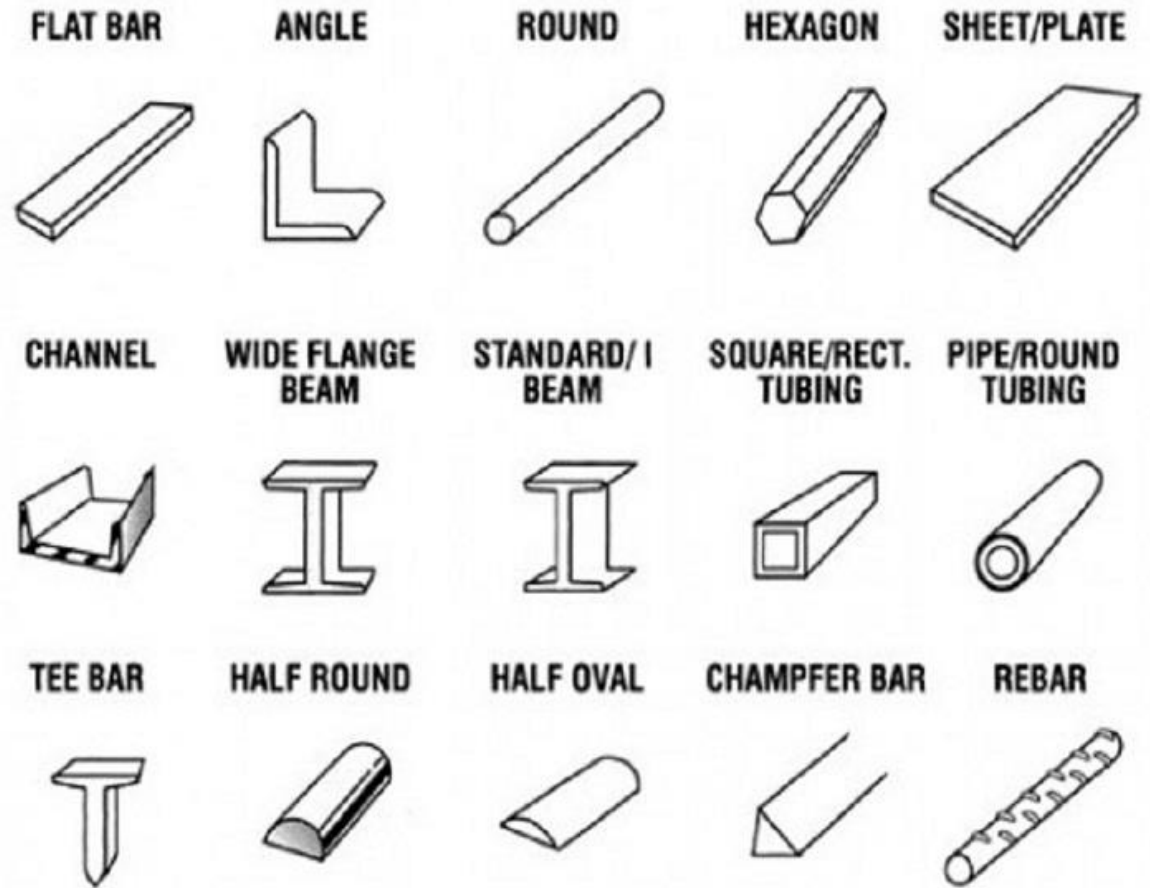

EVALUATION:

- I. List 3 examples of ferrous metals.
- II. Mention 3 types of cast iron.
- III. List 5 furnaces used in metal production.
- IV. State any seven forms of metal.

WEEK NINE

TOPIC: CLAY, CERAMICS, AND GLASS.

Production of non-metallic materials

Processing of ceramics:

In the processing of ceramic materials, mud and clay are obtained and cleared of all the impurities. Afterwards, the materials are mixed with water thoroughly pounded until a smooth, even mixture is obtained. The next process is shaping of the mixture into the desired objects. The art of making moist clay materials into various objects is called **pottery**. There are two methods by which ceramic materials can be processed.

- i. The pinch method
- ii. The potter's wheel method.

The Pinch method: This is the traditional method of using fingers to carefully mould and shape objects.



The Potter's wheel method: This is the method with a rotating disc upon which the clay is mould.



There are 4 stages involved in the production of ceramics:

- i. Molding
- ii. Shaping
- iii. Decorating.
- iv. Firing.

In pottery the following are involved:

- a) Mixing
- b) Shaping
- c) Drying, and
- d) Firing.

Processing of Glass

The mineral glass belongs to the group of ceramics materials; it is made from inorganic resin made from refining petroleum products. Most glasses in use are the inorganic type. Basically, inorganic glass is

produced by melting together various proportions of silica, lime-stone, dolomite by firing them in a furnace. The molten substance is allowed to cool slowly through the process called **Annealing**.

Sub- Topic 2: Plastics and rubber

- I. **Examples of plastics and rubber products.**
- II. **Methods of processing plastics and rubber.**

EXAMPLES OF POLYMER PRODUCTS

S/N	PLASTIC PRODUCTS	RUBBER PRODUCTS
1	Cloth (polyesters)	Tubes and tyres
2	Kitchen Utensils	Gloves
3	Cups, plates and spoons	Boots and raincoats (as well as shoes)
4	Furniture	Balloons and toys
5	Pipes, tubes and accessories for building construction	Adhesive products
6	Bowls, storage drums and containers	Automotive industry products (e.g. hoses, bumpers, dampers, anti-vibration mounts, fan belts, gaskets, etc.)
7	Syringes, and other medical supplies and components	Other personal care products (rubber band, pencils, erasers, hot water bottles)
8	Cases and components of electrical and electronic appliances, etc.	

PLASTICS

Plastics are commonly used both as household items and in big industries. Ordinarily, it is known as a non-metallic lightweight material which comes in various colors. The manufacture of plastics involves the combination of several different components chiefly obtained from petroleum, cellulose, and coal.

Properties of Plastics

- I. Plastics are lightweight materials, much lighter than wood, ceramics and metals.
- II. They have low resistance to heat. They are easily deformed by heat.
- III. They do not rust or corrode.
- IV. They are good insulators of heat and electricity and that is why they are used as handles of pots, pressing irons, plugs.
- V. It can retain its colour for a long period.
- VI. It is very useful in the house as plates, etc.

Classification of Plastics

Plastics are of two types: **Thermoplastics and Thermoset.**

Thermoplastics: These are plastics which become molten again under heat and can therefore be remolded. Examples include most plastic articles used in the homes such as cups, buckets, jerry cans etc.



Thermoset: They are those plastics which cannot be melted into liquid form by heating. Examples are those used in handles of pressing irons, knives and cooking pots. Thermosets are used where high temperature is anticipated.



Manufacturing and Processing of Plastics.

Plastics are derived from organic materials obtained from petroleum. Its production can simply be broken up into the following stages:

- i. Obtaining the basic unit called monomer from petroleum.
- ii. Polymerization (i.e. joining a large number of molecules) of the monomer to form resins.
- iii. Combining the resin with appropriate materials to produce the required plastics.
- iv. Molding and shaping of the plastics into different forms.

Methods of producing plastics

The plastic materials can be molded into any of the required form into any of the required shape when wet through any of the following processes.

- i. The compression moulding
- ii. The Injection moulding

- iii. The Extrusion
- iv. The Calendaring
- v. The vacuum forming.

The compression molding: This is the method of forming plastic materials in a mould by means of the application of pressure and heat energy. This method is employed in forming thermoset plastics.



The injection molding: This is a method of forming an object by injecting hot molten metals by means of plungers.



The Extrusion: This is the method of heating a plastic material and forcing it through a mould followed by continuous cooling. It is a method used in the manufacture of thermoplastic pipes.



The Calendaring: This is a method for producing thermoplastic sheets in paste form between heated and cooled rollers.



The vacuum forming: This is an enclosed method from which air had been completely removed. It is a method for making plastic cups.



RUBBER

is an elastic organic material. Rubber can easily be stretched, and it can return to its original position when the force is released. There are two types of rubber—natural rubber and synthetic rubber.

Properties of Rubber

- I. They are elastic.
- II. They are water resistant and will float on water. This is why they are used as floats for swimming.
- III. They are good electrical insulators. This is why electric wires are covered with rubber.
- IV. It is sturdy and durable.
- V. It can easily absorb pressure.
- VI. It absorbs sound.

Manufacture and Processing of Rubber/ Methods of Processing rubber

Natural rubber is made from latex (a milky white liquid) obtained from the rubber tree- 'Hevea brasiliensis.' Synthetic rubber on the other hand is obtained from petroleum products. **The Natural Latex** as found in nature is a white milky sap like fluid. This is used as the raw material for manufacturing natural Rubber. It is extracted from rubber trees.



The synthetic rubber also called neoprene (artificial rubber) is produced by the combination of various chemicals, coal, lime stone, water and sodium chloride by process called polymerization.



Properties of ordinary rubber are not very desirable since they wear out and scratch easily. It needs to be vulcanized to improve its properties. In vulcanization, sulphur is added to the ordinary rubber at high temperatures in the presence of some other compounds. Rubber products are shaped into their form by a number of processes which you will learn about in future.

Carbon black, produced mainly by burning crude oil in special furnaces, is used in tyre compound as reinforcing filler.

Vulcanization of Rubber: The process of improving the quality of rubber by adding sulphur and other chemicals to rubber so as to make the rubber stronger and more elastic.

Uses of Rubber:

- Rubber is a very good shock absorber and is therefore used for making soles of shoes as well as tyres and inner tubes for motor vehicles
- It is also used for making rubber sandals, rain-boots, catapults, etc.
- For covering electric wires.

The manufacturing of rubber can be processed by any on the following methods:

- i. The vacuum forming



Vacuum compression molding machine Series

ii. The Extrusion



iii. The Calendaring



iv. The compression molding.



Sub-Topic 3

- Advantages and disadvantages of the different processing methods
- Uses of plastic and rubber

ADVANTAGES OF PLASTICS AND RUBBERS

Plastics

1. It is very light than most metals.
2. It can retain its colour for a long period.
3. It is not affected by water.
4. It is not adversely affected by sunlight.

5. It is very useful in the house as plates
6. It is a good insulator.

Rubber

1. It is sturdy and durable
2. It can easily absorb pressure
3. It is a good shock absorber
4. It is not easily affected by light and little heat
5. It is resistant to air, water vapour and sunlight
6. It absorbs sound.
7. It absorbs noise
8. It is a good insulator.

DISADVANTAGES OF PLASTICS AND RUBBERS

Plastics

1. It cannot take intense heat
2. It cannot carry heavy loads like most metals
3. It can tear when subjected to intense pressure
4. If dropped carelessly, it can constitute a nuisance.

Rubber

Its elastic property can be a disadvantage in some cases.

Uses of Plastic

- I. It is used for chairs and tables in homes
- II. It is used as container bags in supermarkets and as pure water container.
- III. It is used as body fender for cars.
- IV. It is used in engines of cars where intense heat is not needed.
- V. It is used where heat is not experienced like the rotor, etc.
- VI. It is used as body parts for most of our musical instruments, piano, flutes and speaker, etc.

Uses of Rubber

- I. It is used as shock absorber.
- II. It is used to carry the engines of a motor and other heavy dead weight.
- III. It is used to absorb sound.
- IV. It is used to absorb light.

Evaluation.

1. State 4 uses of plastics
2. Give 3 properties of plastics
3. Mention any 3 methods of processing plastics

Weekend Assignment

1. State 5 advantages of plastics.
2. Explain any two methods of processing plastics.
3. State 4 uses of rubber.
4. The art of making moist clay materials into various objects is called-----
5. The type of rubber produced from petroleum products is known as-----
6. The natural rubber is made from a white milky liquid content called-----
7. In pottery, clay is mixed with water and pounded to remove-----

Answers: Pottery, Synthetic rubber, Latex, Pebbles.

8. The following are methods of processing plastics EXCEPT
A. Calendaring. B. Extraction C. Injection molding D. Compression molding
E. Vacuum Forming.

WEEK 10 (TEN) REVISION.

WEEK 11 – 13 . (ELEVEN – THIRTEEN) EXAMINATION.